



NORDIK PUMPS



SVM

VERTICAL MULTISTAGE CENTRIFUGAL PUMP

50Hz



CONTENTS

11	SVM/SVMT1	33	SVM/SVMT32
13	SVM/SVMT2	35	SVM/SVM45
15	SVM/SVMT3	37	SVM/SVMT64
17	SVM/SVMT4	39	SVM/SVM90
19	SVM/SVMT5	41	SVM/SVMT100
21	SVM/SVMT8	43	SVM/SVM120
23	SVM/SVMT10	45	SVM/SVMT150
25	SVM/SVMT12	47	SVM/SVM200
27	SVM/SVMT15		
29	SVM/SVMT16		
31	SVM/SVMT20		

Introduction

SVM, SVMT is a high-efficiency and energy-saving vertical multi-stage centrifugal pump. The centrifugal force generated by the impeller of the rotary pump drives the fluid to transfer. Its pump body and motor are composed of main shaft, impeller, diffuser, pump case and mechanical seal, and connected by coupling.

SVM, SVMT series can be used as booster pump alone or as auxiliary booster equipment in the booster system of construction and industry. Its piping structure ensures that the pump is directly installed in the same horizontal piping system with the same diameter in and out. This design makes the structure and piping of the pump more compact.

SVM, SVMT series vertical multi-stage centrifugal pump can be installed vertically or horizontally on pipeline according to different installation space. In the case of horizontal installation, the pump needs to be added with fixed module to ensure the stability of the pump during operation.

Pump material

Cast iron
Stainlesssteel(AISI304/I316)
Duplex stainless steel(2205)

Pipe connection

DIN flange, ANSI flange
Thread
Tri-Clamp
Oval flange

Ambient temperature

If the ambient temperature exceeds the 40 °C or the pump is installed at an altitude exceeding 1000 m, the motor output power P2 will decrease. In such cases, it necessary to use a motor with a higher rated output.

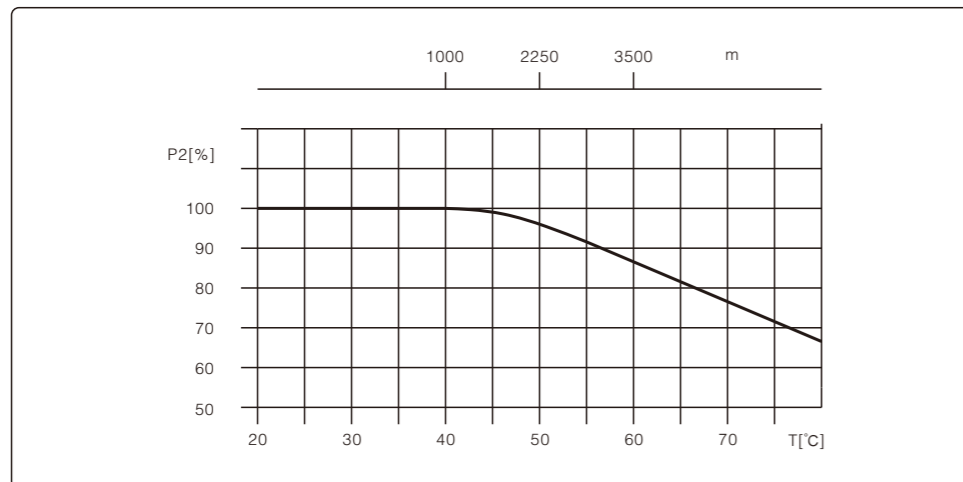

Motor

- Totally enclosed, fan-cooled, 2-pole standard motors
- Enclosure class: IP55
- Insulation class: F
- Voltage: 3x220-240/380-415V
1x220-240V
- Available with single-phase motors(0.37kW-2.2kW)

Liquid temperature °C

- Normal temperature pump: -15°C to +70°C
- Hot temperature pump: -15°C to +120°C

Performance curves

- The motors used for the measurements are based on 2900rpm or 2950 rpm
- Tolerances to ISO 9906
- Measurements have been made with airless water at a temperature of 20 °C
- The curves apply to the following kinematic viscosity: =1 mm²/s
- Select a best efficiency of the pump which is operating within the bold curve of the pump performance.

Pump operating conditions

- Pumping liquids which are thin, clean, non-flammable, non-combustible or non-explosive liquids, not containing solid particles or fibers.
- Maximum ambient temperature: +40 °C
- Maximum altitude above sea level: 1000 m

Pump performance range

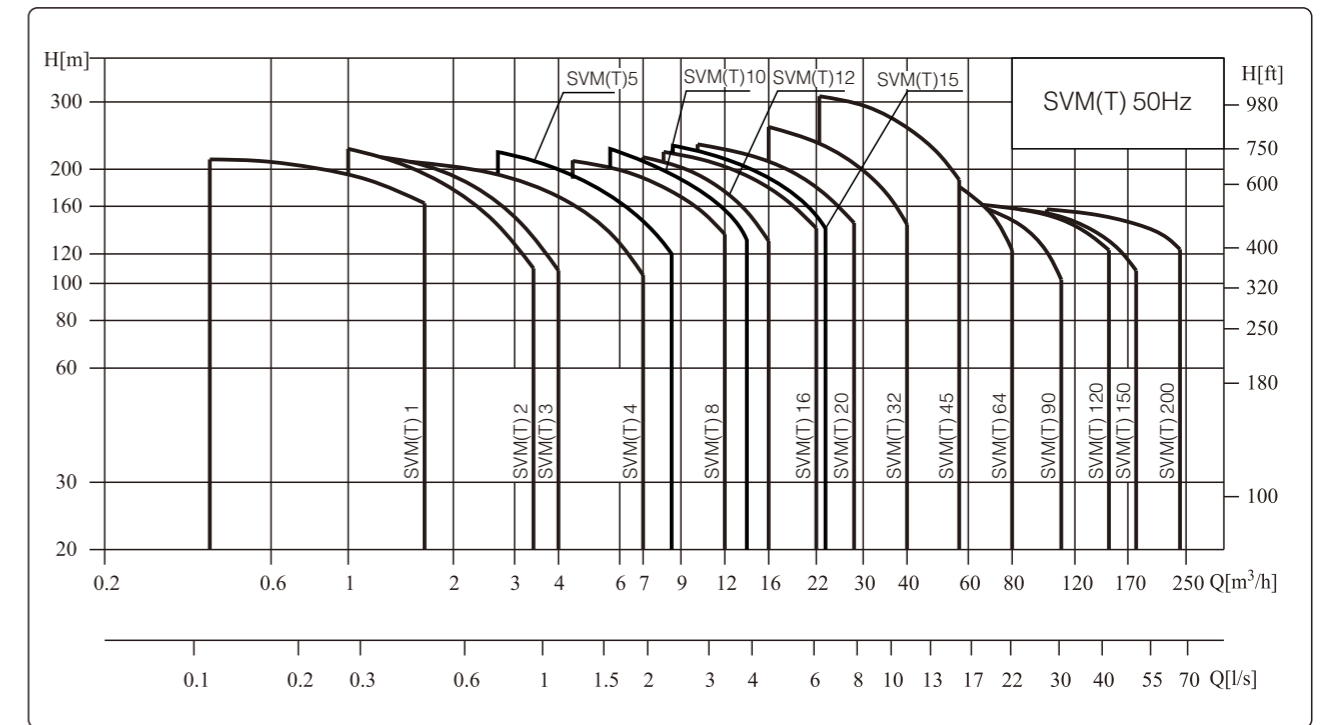

Minimum inlet pressure, NPSH

Cavitation may occur if the following conditions exist during the operation of the water pump:

- The water tank or pool is lower than the water pump inlet;

High liquid temperature;

- Actual flow significantly greater than rated flow;
- Pressure in the pump lower than the vaporization pressure of the conveying liquid.

To avoid cavitation, make sure there is a minimum pressure on the inlet side of the pump. The maximum suction range H (m) can be calculated as follows:

Pb=Atmospheric pressure (atmospheric pressure can be set to 1bar),
in closed system, Pb is system pressure
Hf=Net positive suction head (can be read from the maximum possible flow rate of the pump on the NPSH curve)
Hf=Pipeline loss at inlet
Hv=Vaporization pressure
Hs=Safety margin=Minimum 0.5m head

If the calculated value of H is positive, the pump can be operated at the maximum suction range H.
If the calculated H is negative, there must be a head with minimum inlet pressure H.

Minimum inlet pressure

Definition of model

SVM/SVMT 1,2,3,4,5,8,10,12,15,16,20

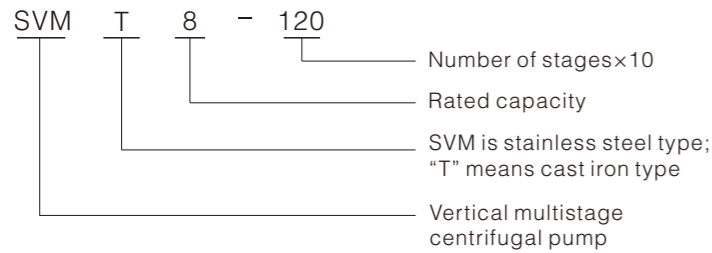

SVM/SVMT 32,45,64,90,120,150

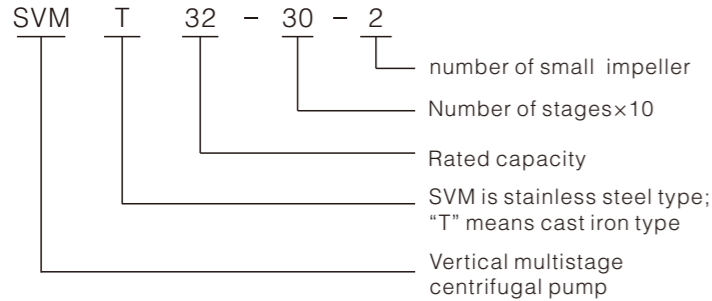

SVM,SVMT 200

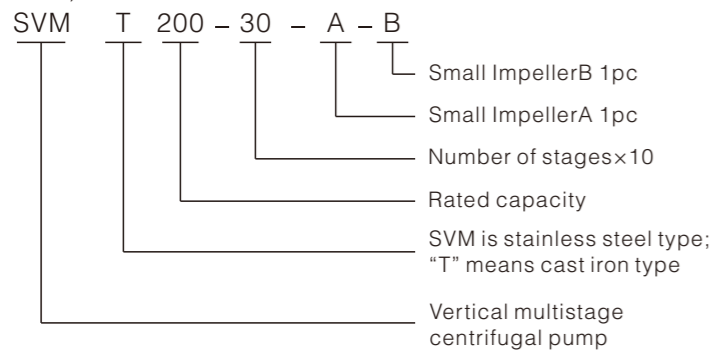

Motor

- Full-enclosed ari-blast two-pole standard motor
- Protection class: IP55
- Insulation class: F
- Standard voltage: 60Hz: 3*220-230/346-440V
3*220-255/380-440V
3*220-277/380-480V

Operation conditions

- Thin, clean, non-flammable and non-explosive liquid containing no solid granules and fibers.
- Liquid temperature:
Normal temperature type: -15°C~+70°C,
Hot water type: -15°C~+120°C
- Ambient temperature: up to +40°C
- Altitude: up to 1000m

Applications

- Water supply
 - Water filter
 - Supercharging
 - Pressurization of hotels
 - Industrial pressurization
- Industrial boosting
 - Cleaning system
 - High pressure flushing system
 - Firefighting system
 - Car cleaning equipment
- Industrial liquid transport
 - Cooling air conditioning system
 - Boiler feed water
 - Condensing system and cooling tower
 - Machine tool cooling lubrication system
- Water treatment
 - Ultrafiltration system
 - Reverse osmosis system
 - Distillation system
 - Separator
 - Swimming pool
- Irrigation
 - Regional irrigation
 - Sprinkler irrigation
 - Drip irrigation
 - Greenhouse irrigation

Max working pressure

The following figure shows the limitation of pressure and temperature, which shall be in the scope as shown in the figure.

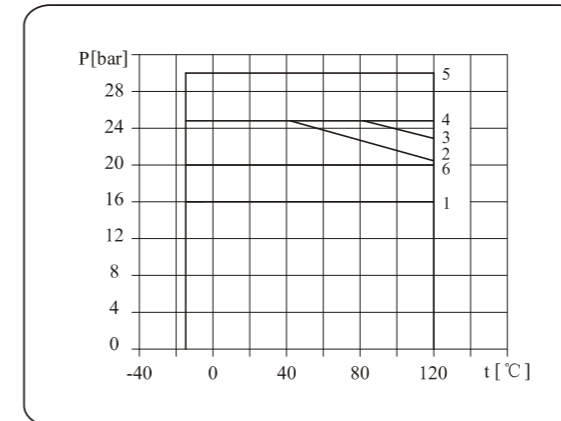

Model	Curve number
SVMT1,2,3,4,5 Flange	2
SVMT1,2,3,4,5 Oval Flange	1
SVM1,2,3,4,5	2
SVMT8,10,12,15,16,20 Flange	3
SVMT8,10,12,15,16,20 Oval Flange	1
SVM 8,10,12,15,16, 20	3
SVM,SVMT 32	
32-10-1~32-50-2	1
32-50~32-90-2	4
32-90~32-100-2	5
SVM,SVMT 45	
45-10-1~45-30	1
45-40-2~45-60	4
45-70-2~45-70	5
SVM,SVMT 64	
64-10-1~64-30	1
64-40-2~64-50-2	4
SVM,SVMT 90	
90-10-1~90-30	1
90-40-2	4
SVM,SVMT 120, 150, 200	6

Max. Ambient temperature

When the pump operates under ambient temperature higher than 40°C or under altitude higher than 1000m, because of low air density and poor cooling effects, the motor output power P2 will be decreased to certain extent. If the pump is operated under the above-said conditions, it should be equipped with motor of higher power.

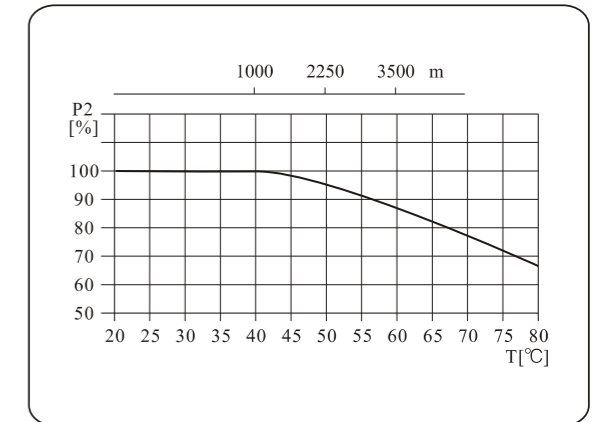

Product range introduction

Parameter	SVM(T)1	SVM(T)2	SVM(T)3	SVM(T)4	SVM(T)5	SVM(T)8	SVM(T)10	SVM(T)12	SVM(T)15	SVM(T)16	SVM(T)20
Rated flow rate [m³/h]	1	2	3	4	5	8	10	12	15	16	20
Rated flow rate [l/s]	0.28	0.56	0.83	1.1	1.39	2.2	2.78	3.3	4.17	4.4	5.6
Flow rate [m³/h]	0.4~1.8	1~3.5	1.2~4	1.5~7	2.5~8.5	5~12	5~13	7~16	8~23	8~22	10~28
Flow rate [l/s]	0.11~0.5	0.28~0.97	0.33~1.1	0.42~1.9	0.69~2.36	1.39~3.3	1.39~3.61	1.9~4.4	2.22~6.39	2.2~6.1	2.8~7.8
Maximum pressure [bar]	21	23	22	21	24	21	23	22	23	22	23
Power [kW]	0.37~2.2	0.37~3	0.37~3	0.37~4	0.37~5.5	0.75~7.5	0.75~7.5	1.5~11	1.1~15	2.2~15	1.1~18.5
Temperature range [°C]	-15~120										
Highest efficiency [%]	44	46	50	58	63	62	70	63	73	66	69
SVM Pipe connection											
DIN flange	DN25	DN25	DN25	DN32	DN32	DN40	DN40	DN50	DN50	DN50	DN50
Thread	R ₁ 1 ¹ / ₄ "	R ₁ 1 ¹ / ₄ "	R ₁ 1 ¹ / ₄ "	R ₁ 1 ¹ / ₄ "	R ₁ 1 ¹ / ₄ "	R ₁ 2"	R ₁ 2"	R ₁ 2"	R ₁ 2"	R ₁ 2"	R ₁ 2"
Clamp connection	DN32	DN32	DN32	DN32	DN32	DN50	DN50	DN50	DN50	DN50	DN50
SVMT Pipe connection											
DIN flange	DN25	DN25	DN25	DN32	DN32	DN40	DN40	DN50	DN50	DN50	DN50
Oval flange	R _p 1	R _p 1	R _p 1	R _p 1 ¹ / ₄	R _p 1 ¹ / ₄	R _p 1 ¹ / ₂	R _p 1 ¹ / ₂	R _p 1 ¹ / ₂	R _p 1 ¹ / ₂	R _p 1 ¹ / ₂	R _p 1 ¹ / ₂

Parameter	SVM/SVMT32	SVM/SVMT45	SVM/SVMT64	SVM/SVMT90	SVM/SVMT120	SVM/SVMT150	SVM/SVMT200
Rated flow rate [m³/h]	32	45	64	90	120	150	200
Rated flow rate [l/s]	8.9	12.5	17.8	25	33.3	41.7	55.6
Flow rate [m³/h]	16~40	25~55	30~80	50~110	60~150	80~180	100~240
Flow rate [l/s]	4.4~11	6.9~15.3	8~22	14~30	17~42	22~50	28~67
Maximum pressure [bar]	26	30	22	17	16	16	16
Power [kW]	1.5~30	3~45	4~45	5.5~45	11~75	11~75	18.5~110
Temperature range [°C]	-15~120						
Highest efficiency [%]	74	75	76	77	74	73	79
Pipe connection							
DIN flange	DN65	DN80	DN100	DN100	DN125	DN125	DN150

Structure SVM/SVMT1,2,3,4,5

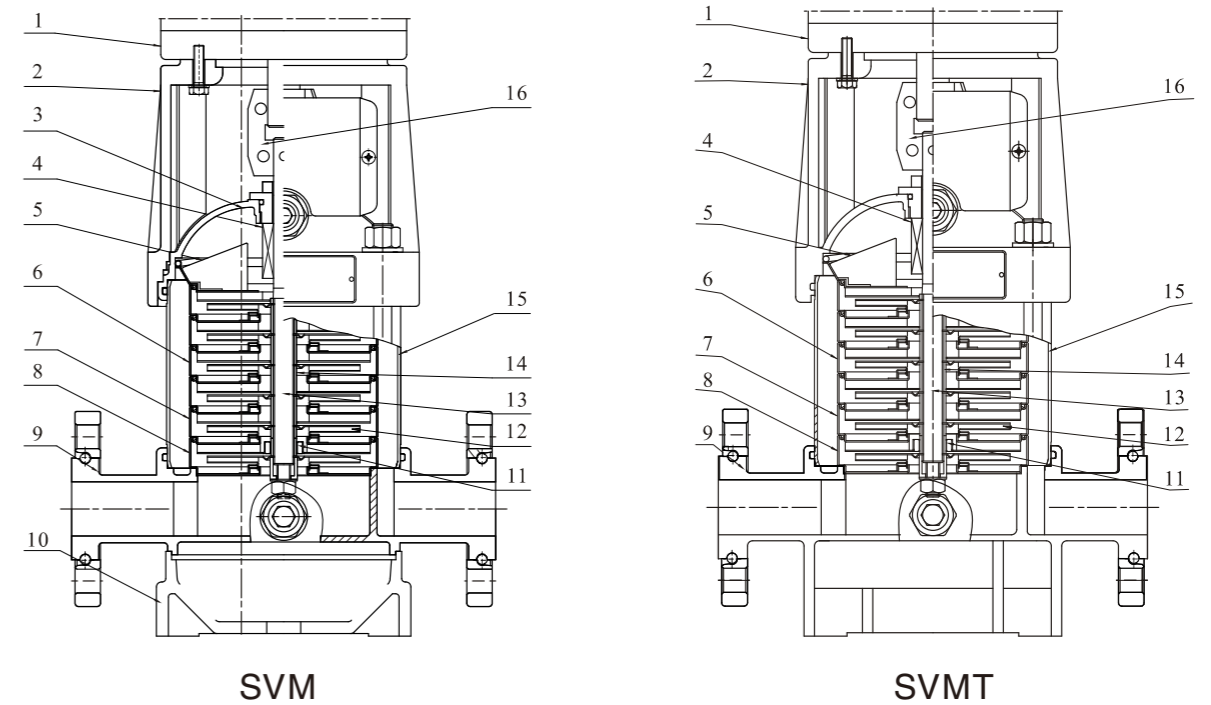

Materials SVM/SVT1,2,3,4,5

No.	Spare parts	Materials		GB		EN DIN		AISI/ASTM	
		SVMT	SVM	SVMT	SVM	SVMT	SVM	SVMT	SVM
1	Motor	/		/		/		/	
2	Bracket	Cast iron /Ductile cast iron		GB9439-HT200 /GB 1348-QT500-7		EN1561 EN-GJL-200 /EN 1563 EN-GJS-500-7		ASTM258 /ASTMA536 65-45-12	
3	Seal base	Stainless steel		GB/T20878-06Cr19Ni10		EN 10088-1.4301		AISI304	
4	Mechanical seal	/		/		/		/	
5	Top diffuser	Stainless steel		GB/T20878-06Cr19Ni10		EN 10088-1.4301		AISI304	
6	Diffuser	Stainless steel		GB/T20878-06Cr19Ni10		EN 10088-1.4301		AISI304	
7	Support diffuser	Stainless steel		GB/T20878-06Cr19Ni10		EN 10088-1.4301		AISI304	
8	Coupling	Ductile cast iron		GB 1348-QT500-7		EN 1563 EN-GJS-500-7		ASTMA536 65-45-12	
9	Impeller	Stainless steel		GB/T20878-06Cr19Ni10		EN 10088-1.4301		AISI304	
10	Cylinder	Stainless steel		GB/T20878-06Cr19Ni10		EN 10088-1.4301		AISI304	
11	Shaft	Stainless steel		GB/T20878-06Cr19Ni10		EN 10088-1.4301		AISI304	
12	Bearing	WC		/		/		/	
13	Inducer	Stainless steel		GB/T20878-06Cr19Ni10		EN 10088-1.4301		AISI304	
14	Inlet&outlet chamber	Cast iron /Stainless steel		GB 9439-HT200 /GB/T20878-06Cr19Ni10		EN 1561 EN-GJL-200 /EN 1563 EN-GJS-500-7		ASTM258 /AISI304	
15	Base	Cast iron		GB 9439-HT200		EN1561 EN-GJL-200		ASTM25B	

Structure SMH/SVMT8,10,12,15,16,20

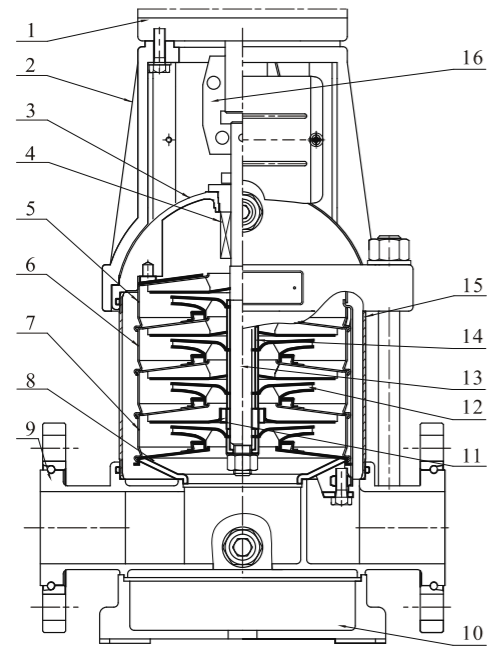

SVM

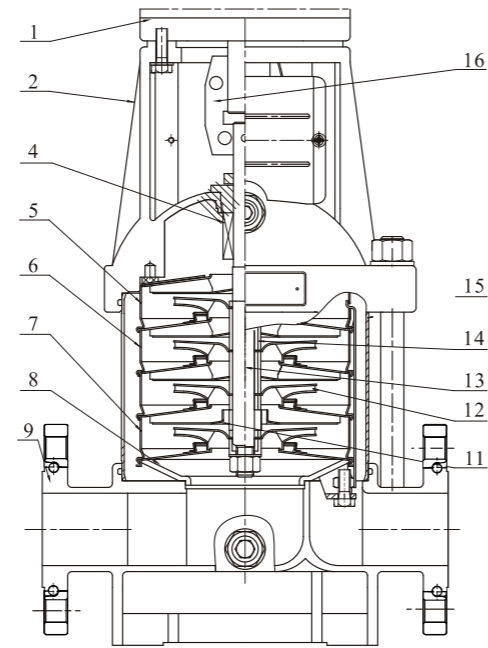

SVMT

Materials SVM/SVMT8,10,12,15,16,20

No.	Spare parts	Materials		GB		EN DIN		AISI/ASTM	
		SVMT	SVM	SVMT	SVM	SVMT	SVM	SVMT	SVM
1	Motor	/		/		/		/	
2	Bracket	Cast iron /Ductile cast iron		GB9439-HT200 /GB 1348-QT500-7		En1561 EN-GJL-200 /EN 1563 EN-GJS-500-7		ASTM258 /ASTMA536 65-45-12	
3	Seal base	Stainless steel		GB/T20878-06Cr19Ni10		EN 10088-1.4301		AISI304	
4	Mechanical seal	/		/		/		/	
5	Top diffuser	Stainless steel		GB/T20878-06Cr19Ni10		EN 10088-1.4301		AISI304	
6	Diffuser	Stainless steel		GB/T20878-06Cr19Ni10		EN 10088-1.4301		AISI304	
7	Support diffuser	Stainless steel		GB/T20878-06Cr19Ni10		EN 10088-1.4301		AISI304	
8	Coupling	Ductile cast iron		GB 1348-QT500-7		EN 1563 EN-GJS-500-7		ASTM A536 65-45-12	
9	Impeller	Stainless steel		GB/T20878-06Cr19Ni10		EN 10088-1.4301		AISI304	
10	Cylinder	Stainless steel		GB/T20878-06Cr19Ni10		EN 10088-1.4301		AISI304	
11	Shaft	Stainless steel		GB/T20878-06Cr19Ni10		EN 10088-1.4301		AISI304	
12	Bearing	WC		/		/		/	
13	Inducer	Stainless steel		GB/T20878-06Cr19Ni10		EN 10088-1.4301		AISI304	
14	Intel&outlet chamber	Cast iron /Stainless steel		GB 9439-HT200 /GB/T20878-06Cr19Ni10		EN 1561 EN-GJL-200 /EN 1563 EN-GJS-500-7		ASTM258 /AISI304	
15	Base	Cast iron		GB 9439-HT200		EN1561 EN-GJL-200		ASTM25B	

Structure SVM/SVMT32,45,64,90

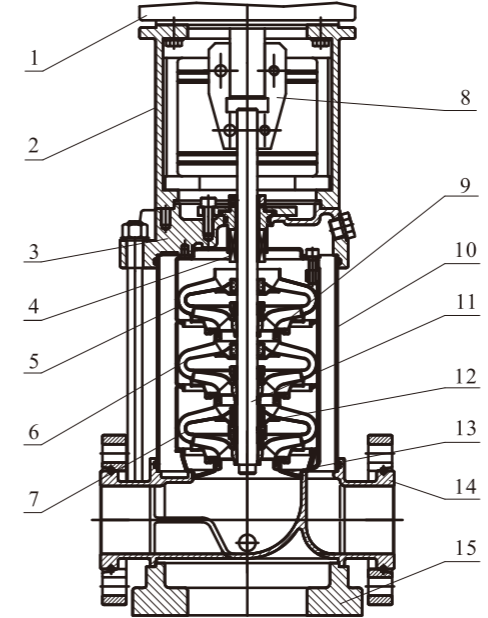

SVM

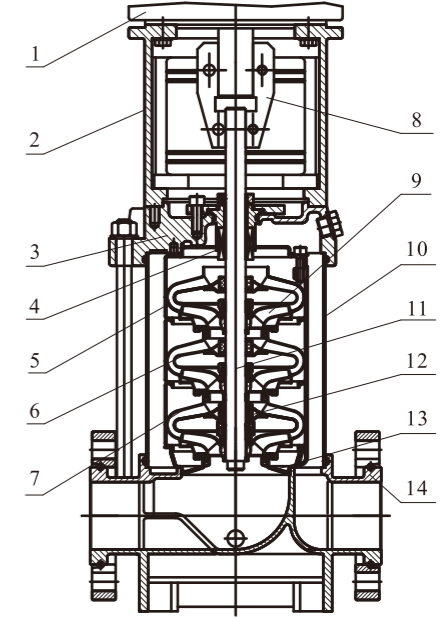

SVMT

Materials SVM/SVMT32,45,64,90

No.	Spare parts	Materials		GB		EN DIN		AISI/ASTM	
		SVMT	SVM	SVMT	SVM	SVMT	SVM	SVMT	SVM
1	Motor	/		/		/		/	
2	Bracket	Cast iron /Ductile cast iron		GB9439-HT200 /GB 1348-QT500-7		EN1561 EN-GJL-200 /EN 1563 EN-GJS-500-7		ASTM258 /ASTMA536 65-45-12	
3	Seal base	Ductile cast iron /Stainless steel		GB 1348-QT500-7 /GB/T20878-06Cr19Ni10		EN 1563 EN-GJS-500-7 /EN 10088-1.4301		STM A536 65-45-12 /AISI304	
4	Mechanical seal	/		/		/		/	
5	Top diffuser	Stainless steel		GB/T20878-06Cr19Ni10		EN 10088-1.4301		AISI304	
6	Diffuser	Stainless steel		GB/T20878-06Cr19Ni10		EN 10088-1.4301		AISI304	
7	Support diffuser	Stainless steel		GB/T20878-06Cr19Ni10		EN 10088-1.4301		AISI304	
8	Coupling	Ductile cast iron		GB 1348-QT500-7		EN 1563 EN-GJS-500-7		ASTM A536 65-45-12	
9	Impeller	Stainless steel		GB/T20878-06Cr19Ni10		EN 10088-1.4301		AISI304	
10	Cylinder	Stainless steel		GB/T20878-06Cr19Ni10		EN 10088-1.4301		AISI304	
11	Shaft	Stainless steel		GB/T20878-06Cr19Ni10		EN 10088-1.4301		AISI304	
12	Bearing	WC		/		/		/	
13	Inducer	Stainless steel		GB/T20878-06Cr19Ni10		EN 10088-1.4301		AISI304	
14	Intel&outlet chamber	Ductile cast iron /Stainless steel		GB 1348-QT500-7 /GB/T20878-06Cr19Ni10		EN 1563 EN-GJS-500-7 /EN 10088-1.4301		STM A536 65-45-12 /AISI304	
15	Base	Cast iron		GB 9439-HT200		EN1561 EN-GJL-200		ASTM25B	

Structure SVM/SVMT120,150,200

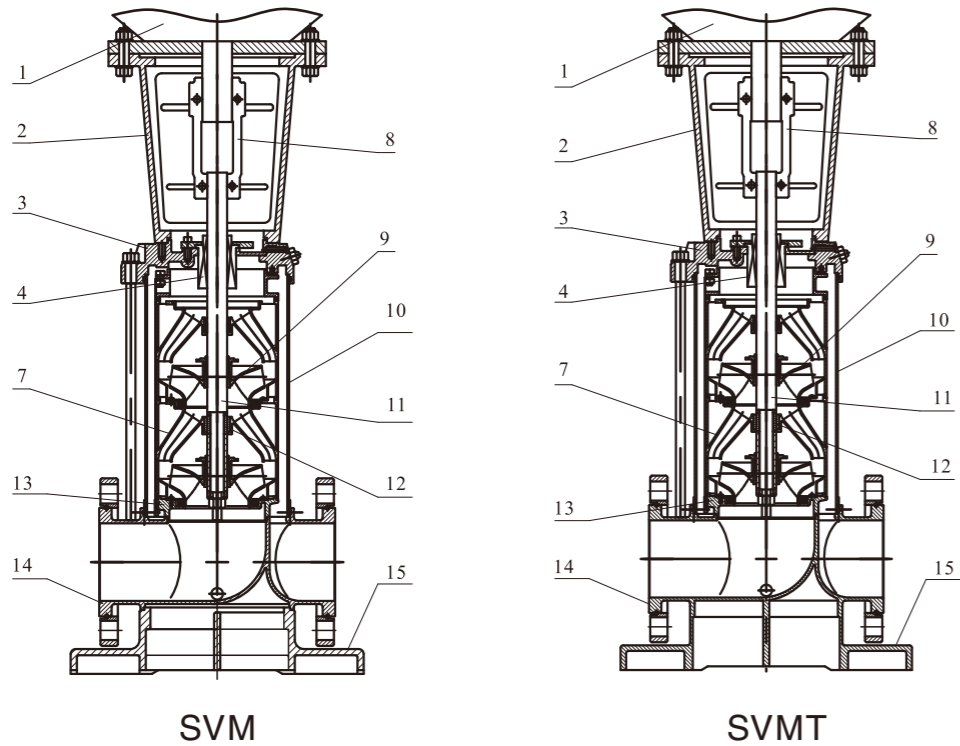

Materials SVM/SVMT120,150,200

No.	Spare parts	Materials		GB		EN DIN		AISI/ASTM	
		SVMT	SVM	SVMT	SVM	SVMT	SVM	SVMT	SVM
1	Motor	/		/		/		/	
2	Bracket	Ductile cast iron /Stainless steel		GB 1348-QT500-7 /GB/T20878-06Cr19Ni10		EN 1563 EN-GJS-500-7 /EN 10088-1.4301		ASTM A536 65-45-12 /AISI304	
3	Seal base	Ductile cast iron /Stainless steel		GB 1348-QT500-7 /GB/T20878-06Cr19Ni10		EN 1563 EN-GJS-500-7 /EN 10088-1.4301		STM A536 65-45-12 /AISI304	
4	Mechanical seal	/		/		/		/	
5	Top diffuser	Stainless steel		GB/T20878-06Cr19Ni10		EN 10088-1.4301		AISI304	
6	Diffuser	Stainless steel		GB/T20878-06Cr19Ni10		EN 10088-1.4301		AISI304	
7	Support diffuser	Stainless steel		GB/T20878-06Cr19Ni10		EN 10088-1.4301		AISI304	
8	Coupling	Ductile cast iron		GB 1348-QT500-7		EN 1563 EN-GJS-500-7		ASTM A536 65-45-12	
9	Impeller	Stainless steel		GB/T20878-06Cr19Ni10		EN 10088-1.4301		AISI304	
10	Cylinder	Stainless steel		GB/T20878-06Cr19Ni10		EN 10088-1.4301		AISI304	
11	Shaft	Stainless steel		GB/T20878-06Cr19Ni10		EN 10088-1.4301		AISI304	
12	Bearing	WC		/		/		/	
13	Inducer	Stainless steel		GB/T20878-06Cr19Ni10		EN 10088-1.4301		AISI304	
14	Intel&outlet chamber	Ductile cast iron /Stainless steel		GB 1348-QT500-7 /GB/T20878-06Cr19Ni10		EN 1563 EN-GJS-500-7 /EN 10088-1.4301		STM A536 65-45-12 /AISI304	
15	Base	Cast iron		GB 9439-HT200		EN1561 EN-GJL-200		ASTM25B	

Curve charts reading

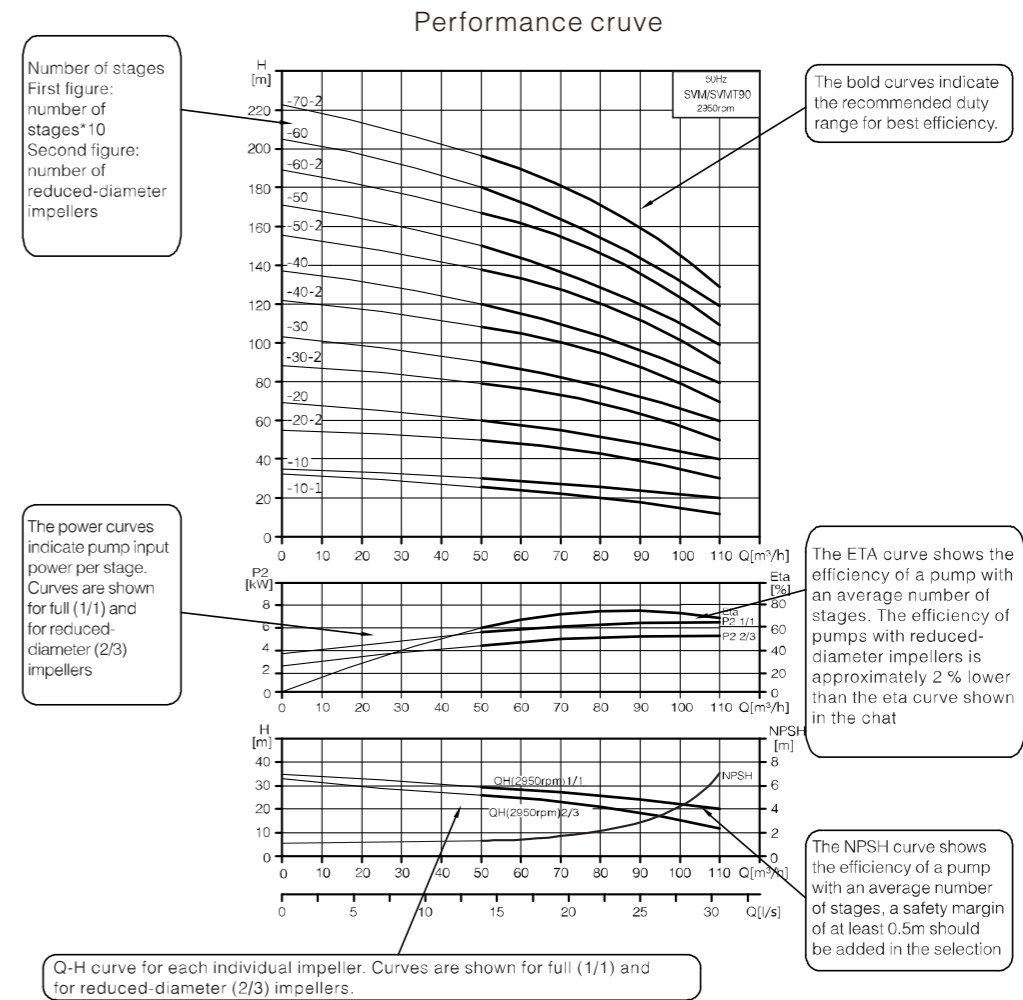

Installation dimensions and weight

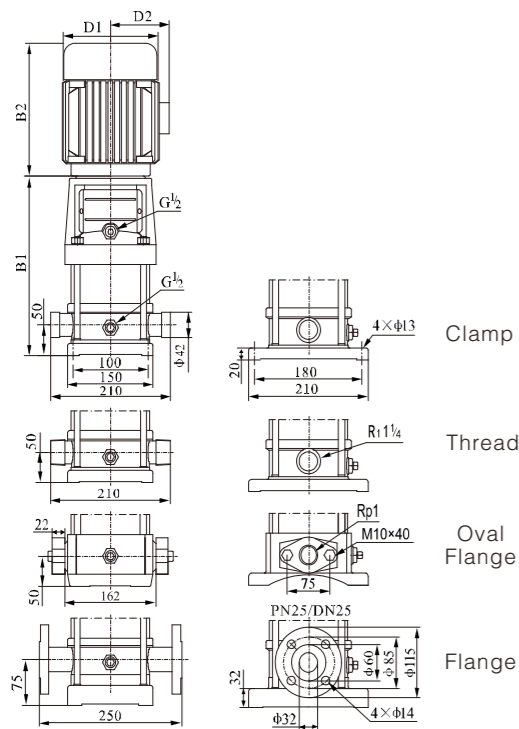

Model	Dimension (mm)					Weight (kg)
	B1	B2	B1+B2	D1	D2	
SVM(T)1-20	258	239	497	148	117	20
SVM(T)1-30	276	239	515	148	117	20
SVM(T)1-40	294	239	533	148	117	21
SVM(T)1-50	312	239	551	148	117	21
SVM(T)1-60	330	239	569	148	117	22
SVM(T)1-70	348	239	587	148	117	23
SVM(T)1-80	366	239	605	148	117	24
SVM(T)1-90	384	239	623	148	117	25
SVM(T)1-100	402	239	641	148	117	26
SVM(T)1-110	420	239	659	148	117	26
SVM(T)1-120	448	280	728	170	142	29
SVM(T)1-130	466	280	746	170	142	30
SVM(T)1-150	502	280	782	170	142	31
SVM(T)1-170	538	280	818	170	142	33
SVM(T)1-190	574	280	854	170	142	34
SVM(T)1-210	610	280	890	170	142	35
SVM(T)1-230	646	280	926	170	142	36
SVM(T)1-250	692	333	1025	190	155	42
SVM(T)1-270	728	333	1061	190	155	43
SVM(T)1-300	782	333	1115	190	155	45
SVM(T)1-330	836	333	1169	190	155	49
SVM(T)1-360	890	333	1223	190	155	51

Performance data

Model	Power		Q (m³/h)	H (m)																
	kW	Hp		0.4	0.6	0.8	1.0	1.2	1.4	1.6	1.8									
SVM(T)1-20	0.37	0.5	13	12.5	12	11.5	11	10.5	10	9.5										
SVM(T)1-30	0.37	0.5	19	18	17.5	17	16.5	16	15	14										
SVM(T)1-40	0.37	0.5	24	23.5	23	22.5	21.5	21	19	18										
SVM(T)1-50	0.37	0.5	30	29.6	29	28	27	26	24	22										
SVM(T)1-60	0.37	0.5	36	35.5	35	33.5	33	31	28	26										
SVM(T)1-70	0.37	0.5	42	41	40.5	39	38	36	33	30										
SVM(T)1-80	0.55	0.75	48	47	46	45	43	41	38	34										
SVM(T)1-90	0.55	0.75	54	53	52	51	49	46	43	39										
SVM(T)1-100	0.55	0.75	60	59	58	57	54	51	48	43										
SVM(T)1-110	0.55	0.75	66	65	63	61	59	56	52	47										
SVM(T)1-120	0.75	1	72	71	69	67	64	61	57	51										
SVM(T)1-130	0.75	1	78	77	75	73	69	66	62	55										
SVM(T)1-150	0.75	1	89	88	86	84	79	76	71	63										
SVM(T)1-170	1.1	1.5	101	99	97	95	89	86	80	71										
SVM(T)1-190	1.1	1.5	113	110	108	106	99	96	89	79										
SVM(T)1-210	1.1	1.5	124	122	120	117	110	106	98	87										
SVM(T)1-230	1.1	1.5	137	133	131	128	121	116	107	96										
SVM(T)1-250	1.5	2	149	145	143	139	131	126	116	104										
SVM(T)1-270	1.5	2	161	157	155	150	141	136	125	112										
SVM(T)1-300	1.5	2	178	175	171	166	157	150	139	124										
SVM(T)1-330	2.2	3	196	192	188	183	173	165	154	137										
SVM(T)1-360	2.2	3	214	210	205	200	190	181	169	151										

Performance curve

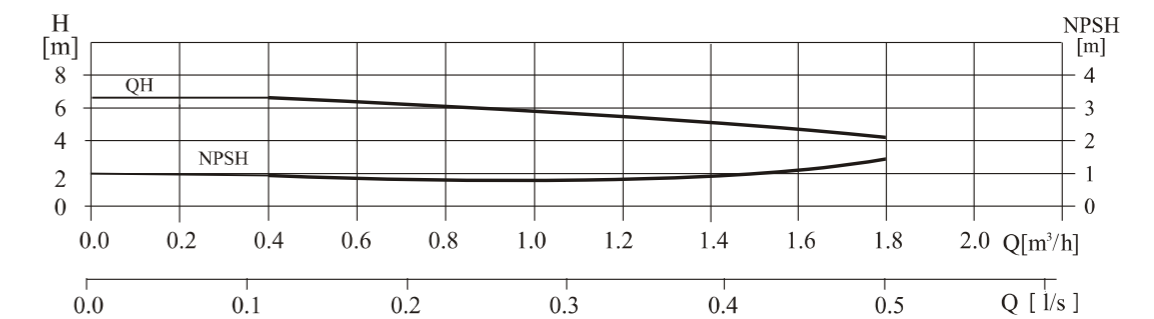
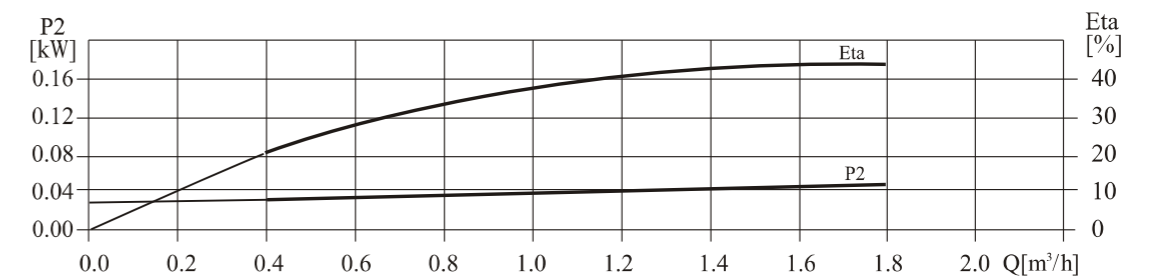
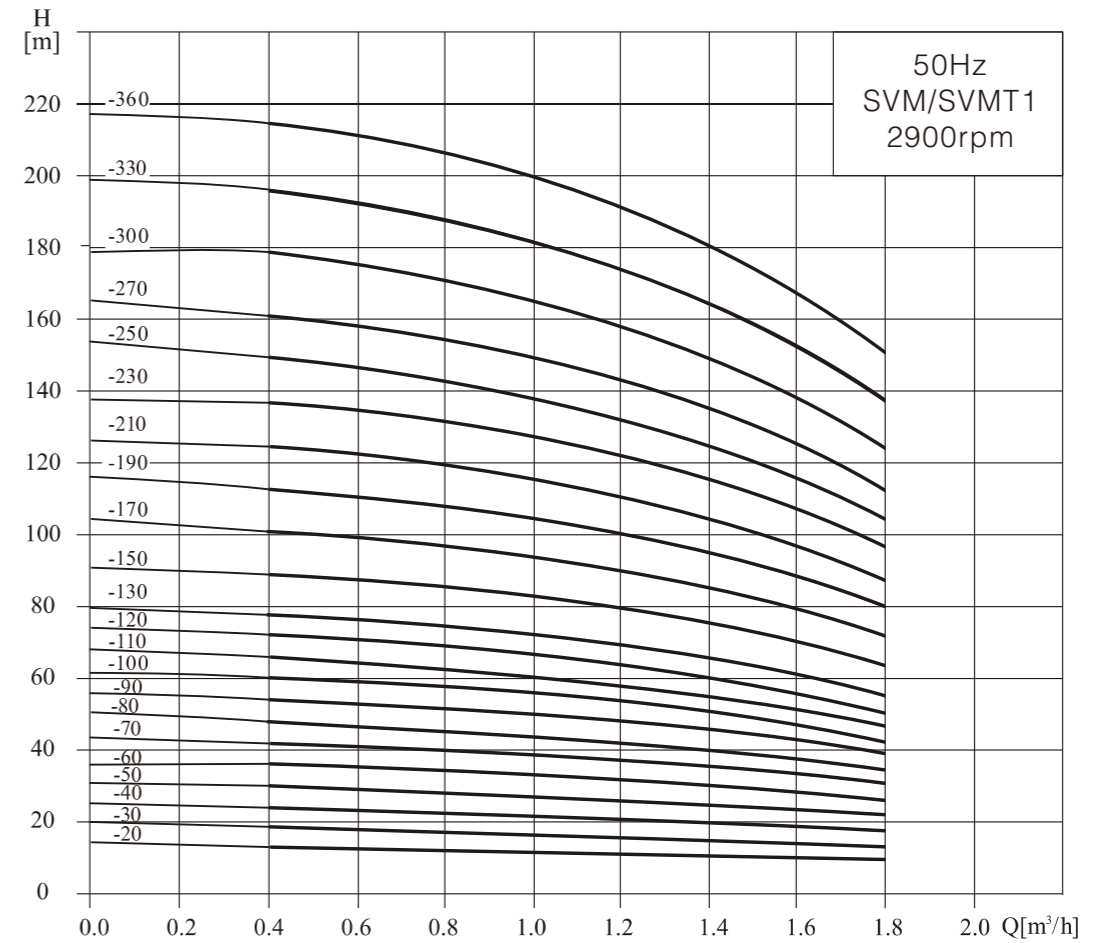

Installation dimensions and weight

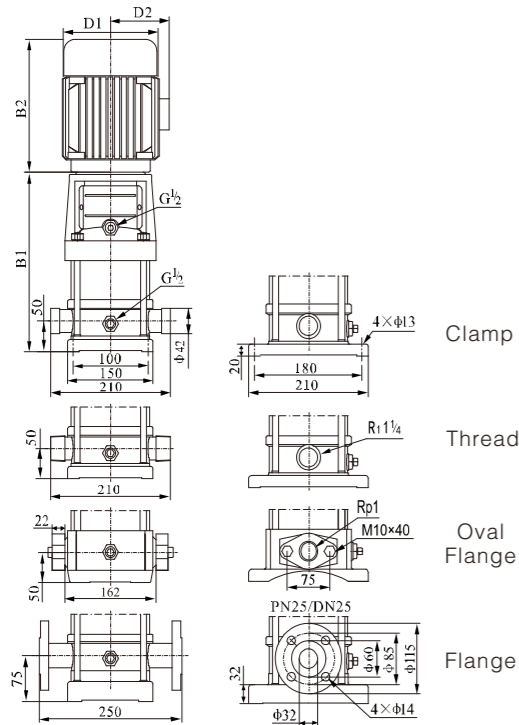

Model	Dimension (mm)					Weight (kg)
	B1	B2	B1+B2	D1	D2	
SVM(T)2-20	258	239	497	148	117	20
SVM(T)2-30	276	239	515	148	117	20
SVM(T)2-40	294	239	533	148	117	22
SVM(T)2-50	312	239	551	148	117	23
SVM(T)2-60	340	280	620	170	142	26
SVM(T)2-70	358	280	638	170	142	26
SVM(T)2-90	394	280	674	170	142	28
SVM(T)2-110	430	280	710	170	142	29
SVM(T)2-130	476	333	809	190	155	35
SVM(T)2-150	512	333	845	190	155	36
SVM(T)2-180	566	333	899	190	155	41
SVM(T)2-220	638	333	971	190	155	42
SVM(T)2-260	720	348	1068	197	165	52

Performance data

Model	Power		Q (m³/h)	H (m)																	
	kW	Hp		1	1.2	1.6	2.0	2.4	2.8	3.2	3.5										
SVM(T)2-20	0.37	0.5	18	17	16	15	13	12	10	8											
SVM(T)2-30	0.37	0.5	27	26	24	22	20	18	15	12											
SVM(T)2-40	0.55	0.75	36	35	33	30	26	24	20	16											
SVM(T)2-50	0.55	0.75	45	43	40	37	33	30	24	20											
SVM(T)2-60	0.75	1	53	52	50	45	40	36	30	24											
SVM(T)2-70	0.75	1	63	61	57	52	47	41	35	28											
SVM(T)2-90	1.1	1.5	80	78	73	67	61	54	45	37											
SVM(T)2-110	1.1	1.5	98	95	89	82	73	64	54	44											
SVM(T)2-130	1.5	5	116	114	106	98	89	78	65	52											
SVM(T)2-150	1.5	5	134	130	123	112	100	90	73	60											
SVM(T)2-180	2.2	3	161	157	148	136	121	108	91	76											
SVM(T)2-220	2.2	3	197	192	180	165	148	130	110	90											
SVM(T)2-260	3.0	4	232	228	214	198	179	158	130	110											

Performance curve

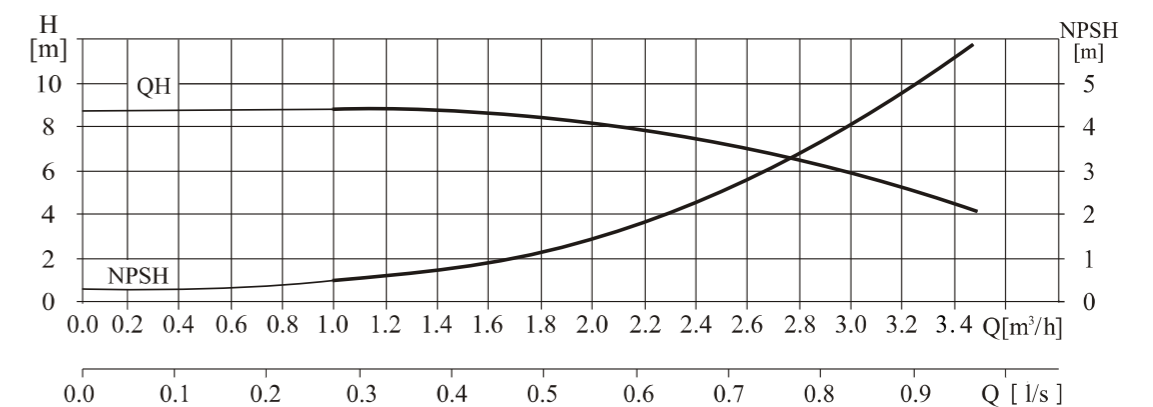
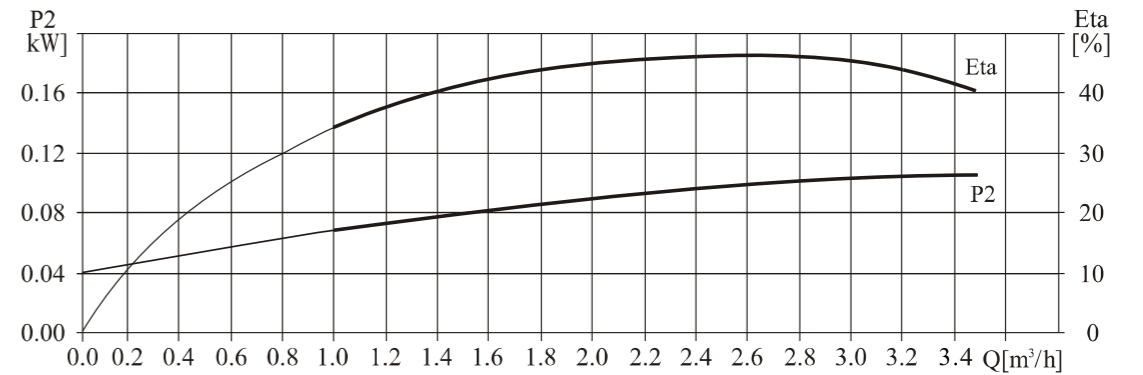
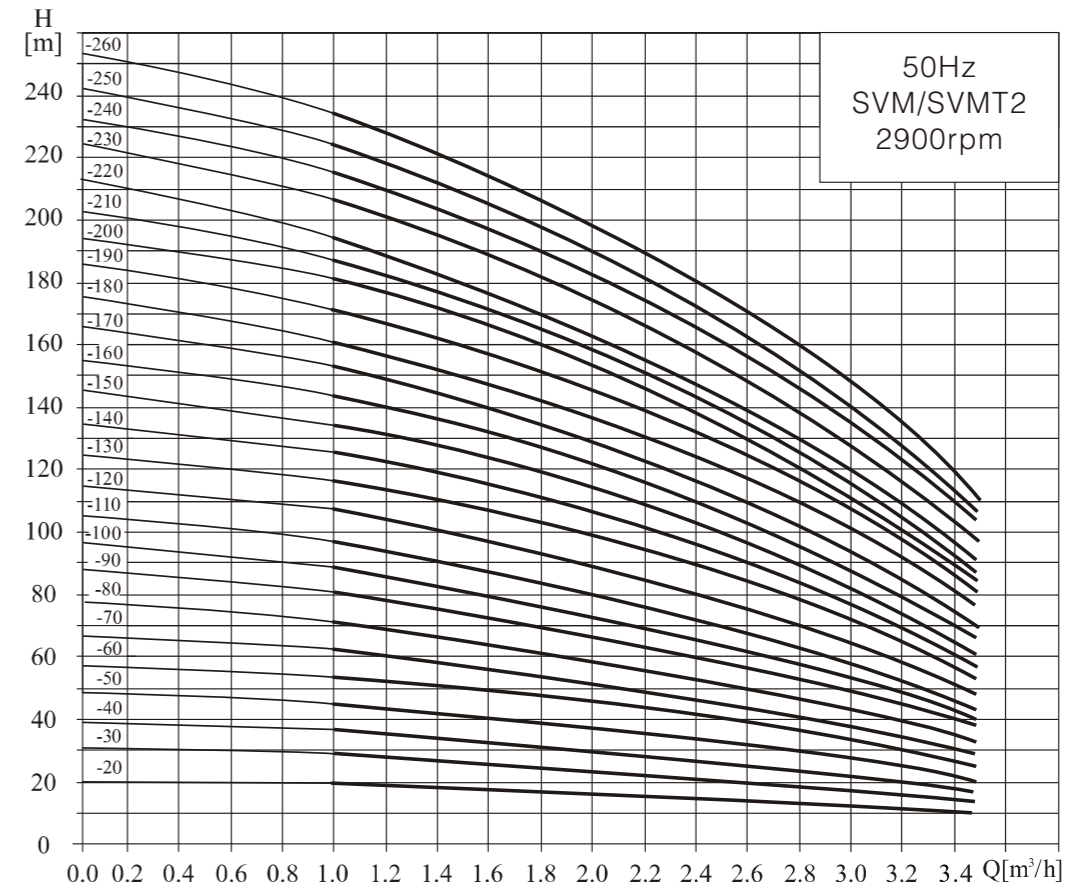

Installation dimensions and weight

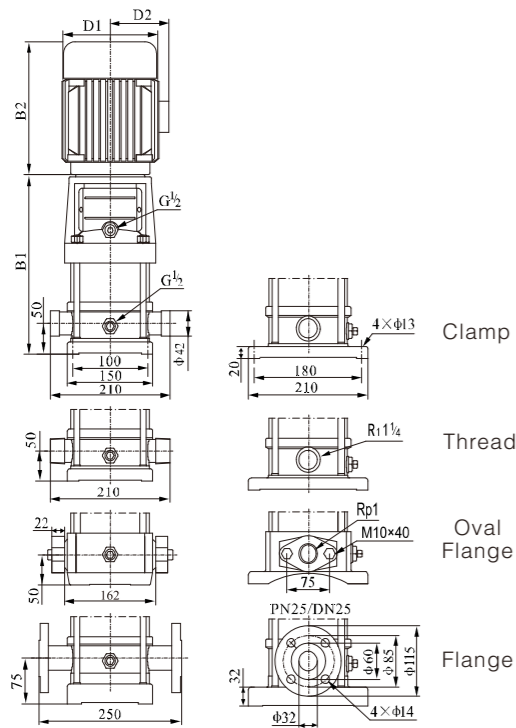

Model	Dimension (mm)					Weight (kg)
	B1	B2	B1+B2	D1	D2	
SVM(T)3-20	258	239	497	148	117	20
SVM(T)3-30	276	239	515	148	117	20
SVM(T)3-40	294	239	533	148	117	21
SVM(T)3-50	312	239	551	148	117	21
SVM(T)3-60	330	239	569	148	117	23
SVM(T)3-70	348	239	587	148	117	24
SVM(T)3-80	376	280	656	170	142	27
SVM(T)3-90	394	280	674	170	142	28
SVM(T)3-100	412	280	692	170	142	28
SVM(T)3-110	430	280	710	170	142	29
SVM(T)3-120	448	280	728	170	142	30
SVM(T)3-130	466	280	746	170	142	31
SVM(T)3-150	502	280	782	170	142	32
SVM(T)3-170	548	333	881	190	155	38
SVM(T)3-190	584	333	917	190	155	39
SVM(T)3-210	620	333	953	190	155	42
SVM(T)3-230	656	333	989	190	155	43
SVM(T)3-250	692	333	1025	190	155	44
SVM(T)3-270	728	333	1061	190	155	45
SVM(T)3-290	764	333	1097	190	155	46
SVM(T)3-310	810	348	1158	197	165	54
SVM(T)3-330	846	348	1194	197	165	55
SVM(T)3-360	900	348	1248	197	165	57

Performance data

Model	Power		Q (m³/h)	H (m)										
	kW	Hp		1.2	1.6	2.0	2.4	2.8	3.0	3.2	3.6	4.0		
SVM(T)3-20	0.37	0.5	H (m)	12.5	11.5	11	10.5	10	9	8	7	6		
SVM(T)3-30	0.37	0.5		19	18.5	17.5	16.5	15	14	13	11	9		
SVM(T)3-40	0.37	0.5		25	24	23	21.5	20	19	18	15	12		
SVM(T)3-50	0.37	0.5		31	30	29	27	25	23	22	19	16		
SVM(T)3-60	0.55	0.75		36	35	34	32	30	28	27	23	19		
SVM(T)3-70	0.55	0.75		43	41	39	37	34	32	31	27	22		
SVM(T)3-80	0.75	1		49	47	45	43	39	37	35	31	25		
SVM(T)3-90	0.75	1		55	53	51	48	45	42	40	35	28		
SVM(T)3-100	0.75	1		61	59	57	54	50	47	45	39	31		
SVM(T)3-110	1.1	1.5		67	64	61	58	54	51	49	42	34		
SVM(T)3-120	1.1	1.5		73	70	67	63	58	55	52	45	37		
SVM(T)3-130	1.1	1.5		78	76	73	69	64	60	57	49	40		
SVM(T)3-150	1.1	1.5		90	88	84	79	73	69	66	57	46		
SVM(T)3-170	1.5	2		103	100	96	90	83	79	75	64	52		
SVM(T)3-190	1.5	2		115	112	107	100	92	88	83	72	58		
SVM(T)3-210	2.2	3		128	124	119	112	102	98	91	79	64		
SVM(T)3-230	2.2	3		140	135	130	122	112	107	100	86	70		
SVM(T)3-250	2.2	3		151	147	141	131	122	116	109	94	76		
SVM(T)3-270	2.2	3		164	159	152	143	132	124	117	101	82		
SVM(T)3-290	2.2	3		175	170	163	153	142	133	126	109	88		
SVM(T)3-310	3.0	4	187	182	175	165	153	142	135	116	94			
SVM(T)3-330	3.0	4	199	194	187	176	163	151	145	125	100			
SVM(T)3-360	3.0	4	218	212	204	192	178	168	159	137	109			

Performance curve

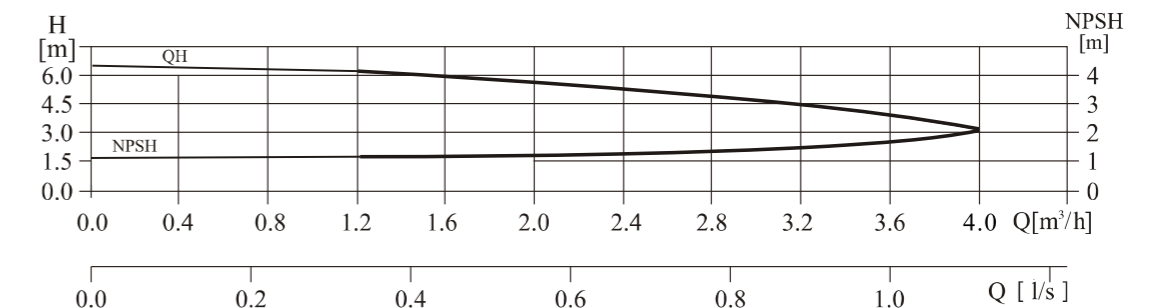
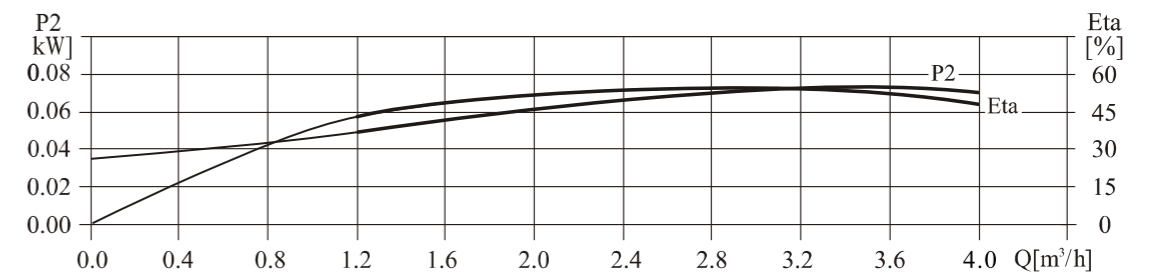
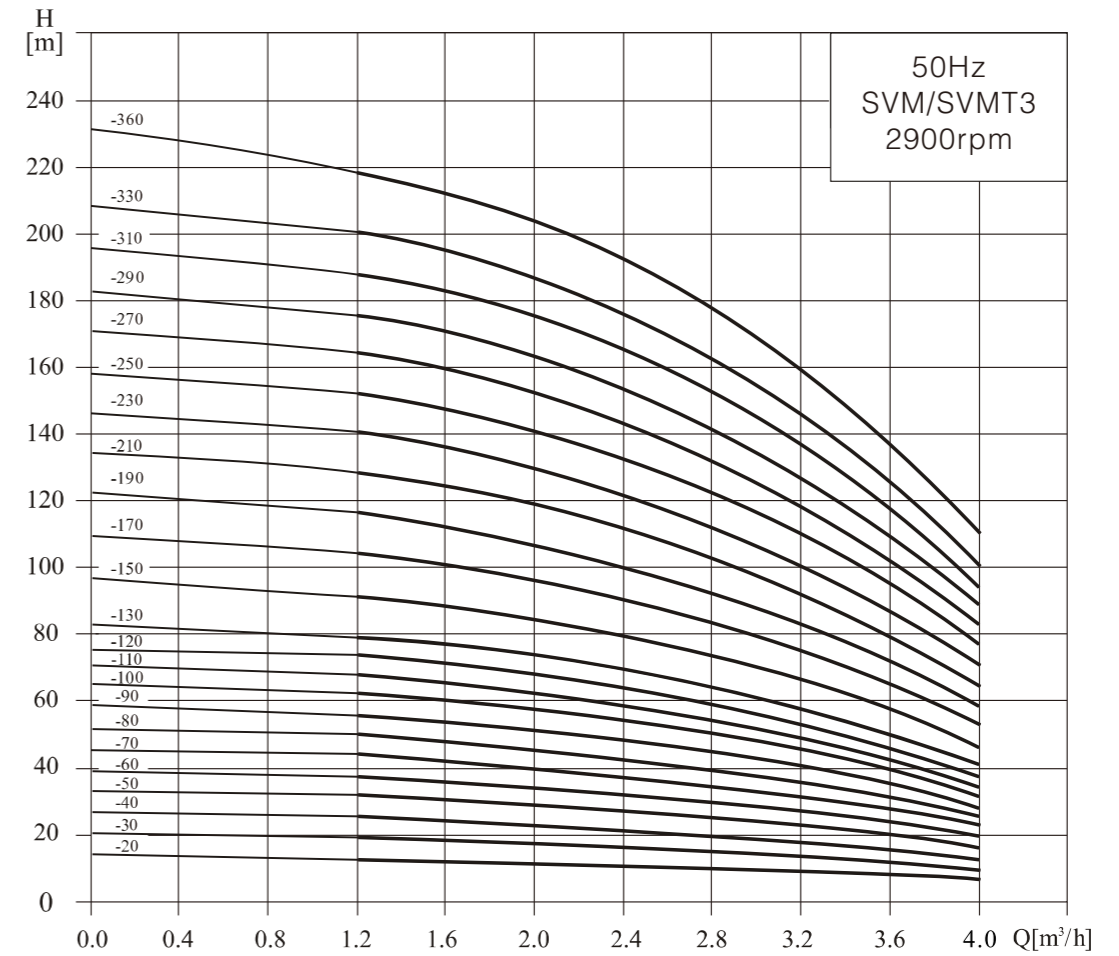

Installation dimensions and weight

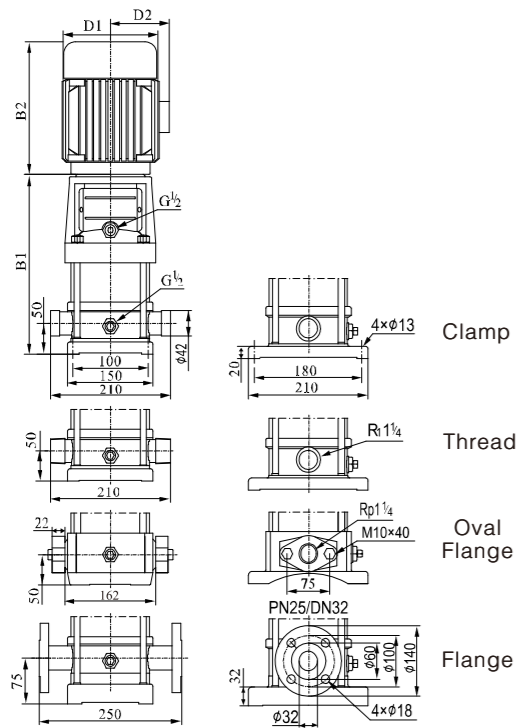

Model	Dimension (mm)					Weight (kg)
	B1	B2	B1+B2	D1	D2	
SVM(T)4-20	276	239	515	148	117	21
SVM(T)4-30	303	239	542	148	117	22
SVM(T)4-40	340	280	620	170	142	25
SVM(T)4-50	367	280	647	170	142	27
SVM(T)4-60	394	280	674	170	142	27
SVM(T)4-70	431	333	764	190	155	33
SVM(T)4-80	458	333	791	190	155	33
SVM(T)4-100	512	333	845	190	155	37
SVM(T)4-120	566	333	899	190	155	38
SVM(T)4-140	630	348	978	197	165	46
SVM(T)4-160	684	348	1032	197	165	48
SVM(T)4-190	765	382	1147	230	188	57
SVM(T)4-220	846	382	1228	230	188	59

Performance data

Model	Power		Q (m³/h)	H (m)						
	kW	Hp		1.5	2.0	3.0	4.0	5.0	6.0	7.0
SVM(T)4-20	0.37	0.5	19	18	17	15	13	10	8	
SVM(T)4-30	0.55	0.75	28	27	26	24	20	18	13	
SVM(T)4-40	0.75	1	38	36	34	32	27	24	19	
SVM(T)4-50	1.1	1.5	47	45	43	40	34	31	23	
SVM(T)4-60	1.1	1.5	56	54	52	48	41	37	28	
SVM(T)4-70	1.5	2	66	63	61	56	48	43	33	
SVM(T)4-80	1.5	2	74	72	70	64	55	50	38	
SVM(T)4-100	2.2	3	96	90	87	81	71	62	48	
SVM(T)4-120	2.2	3	114	108	104	95	85	75	58	
SVM(T)4-140	3.0	4	136	126	122	112	101	89	68	
SVM(T)4-160	3.0	4	152	144	140	129	115	101	78	
SVM(T)4-190	4.0	5.5	183	171	168	153	137	122	93	
SVM(T)4-220	4.0	5.5	211	200	192	178	160	138	108	

Performance curve

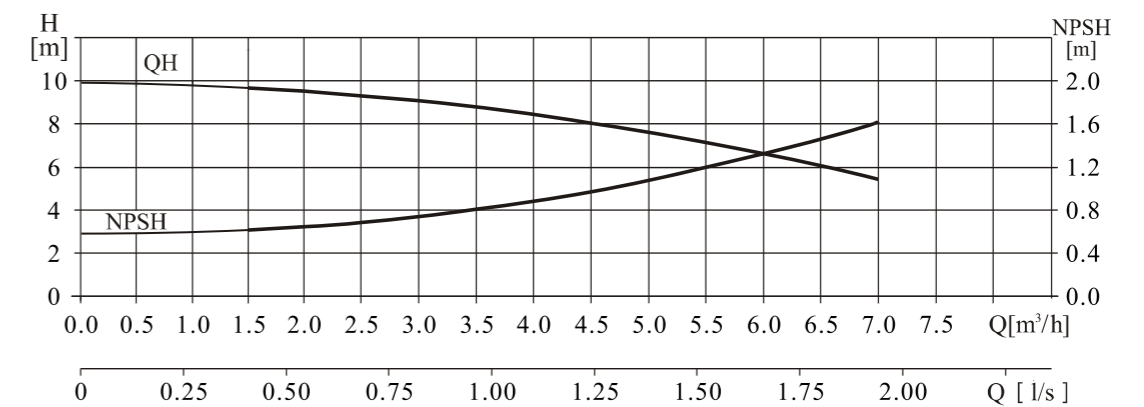
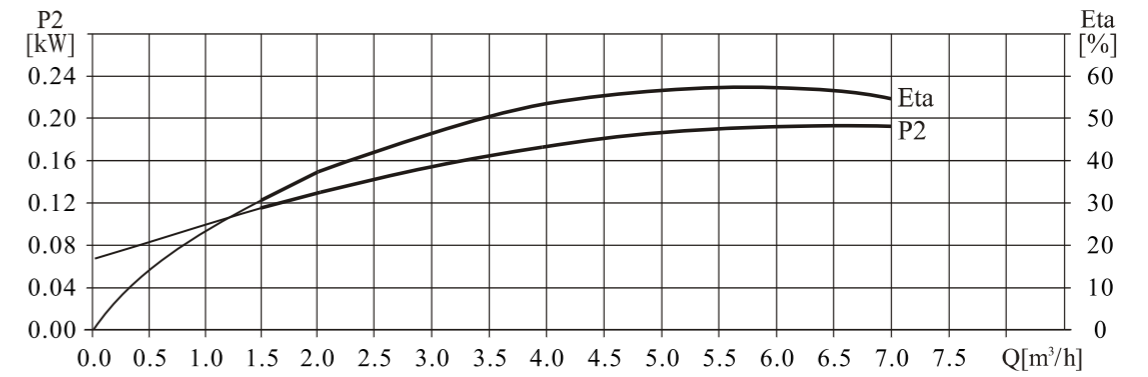
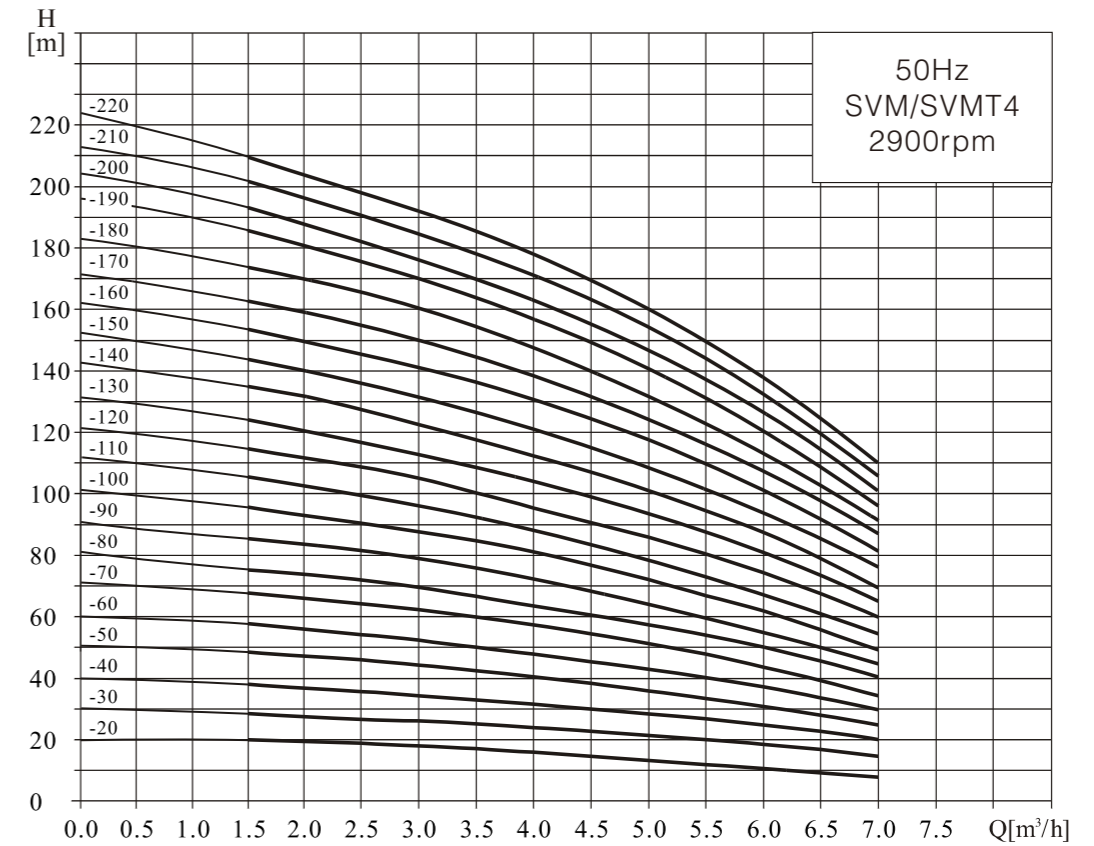

Installation dimensions and weight

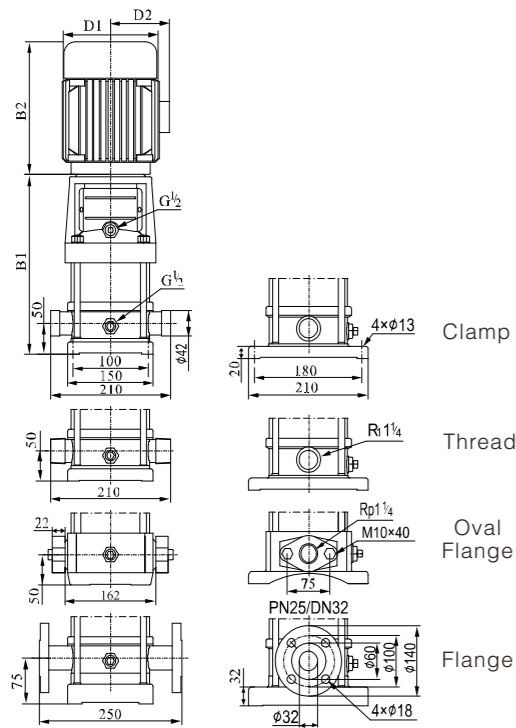

Model	Dimension (mm)					Weight (kg)
	B1	B2	B1+B2	D1	D2	
SVM(T)5-20	276	239	515	148	117	21
SVM(T)5-30	303	239	541	148	117	22
SVM(T)5-40	330	239	569	148	117	23
SVM(T)5-50	367	280	647	170	142	25
SVM(T)5-60	394	280	674	170	142	26
SVM(T)5-80	448	280	728	170	142	27
SVM(T)5-100	512	333	845	190	155	33
SVM(T)5-120	566	333	899	190	155	37
SVM(T)5-140	620	333	953	190	155	38
SVM(T)5-160	674	333	1007	190	155	39
SVM(T)5-180	738	348	1086	197	165	48
SVM(T)5-200	792	348	1140	197	165	49
SVM(T)5-220	846	382	1228	230	185	57
SVM(T)5-240	900	382	1282	230	185	58
SVM(T)5-260	954	382	1336	230	185	59
SVM(T)5-290	1035	382	1417	230	185	60
SVM(T)5-320	1136	435	1571	260	210	75
SVM(T)5-360	1244	435	1679	260	210	76

Performance data

Model	Power		Q (m³/h)	H (m)					
	kW	Hp		2.5	4	5	6	7	8.5
SVM(T)5-20	0.37	0.5	12.5	11.5	10.5	9	7	3.5	
SVM(T)5-30	0.55	0.75	19.5	17.5	15.5	13.5	11	6	
SVM(T)5-40	0.55	0.75	26	23.5	21	18.5	15	8.5	
SVM(T)5-50	0.75	1	32.5	29.5	26.5	23	18.5	11	
SVM(T)5-60	1.1	1.5	38.5	34.5	31.5	28	23	14	
SVM(T)5-80	1.1	1.5	50.5	46	42.5	38	31.5	20	
SVM(T)5-100	1.5	2	63.5	58.5	54	48	41	27.5	
SVM(T)5-120	2.2	3	76	71	65.5	58.5	50.5	35	
SVM(T)5-140	2.2	3	89	82	76.5	68	58.5	40	
SVM(T)5-160	2.2	3	101	94	87	77.5	66.5	46	
SVM(T)5-180	3.0	4	115	107	99	88.5	77	53	
SVM(T)5-200	3.0	4	129	120	112	100	87	62	
SVM(T)5-220	4.0	5.5	142	132	123	111	96	69	
SVM(T)5-240	4.0	5.5	156	144	134	121	105	75.5	
SVM(T)5-260	4.0	5.5	169	157	145	131	113	81	
SVM(T)5-290	4.0	5.5	189	175	162	146	125	88	
SVM(T)5-320	5.5	7.5	209	194	180	162	141	102	
SVM(T)5-360	5.5	7.5	232	216	201	181	158	114	

Performance cruve

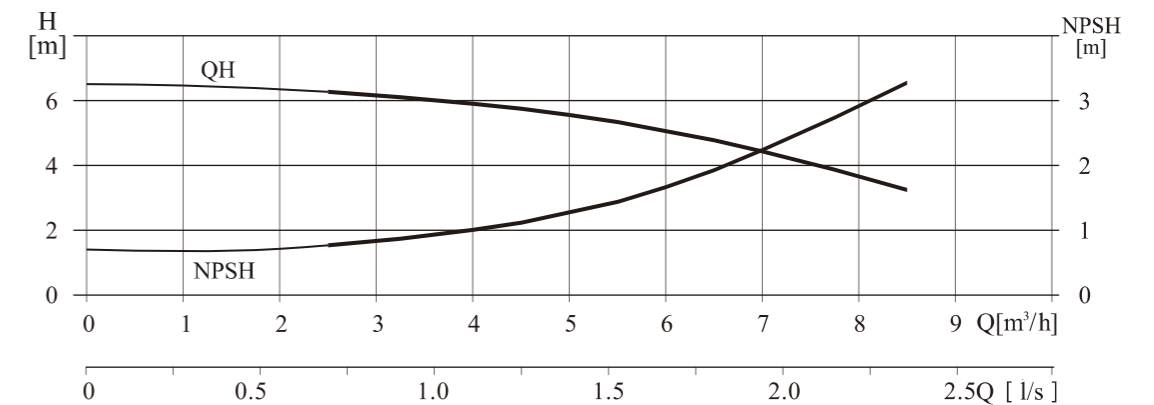
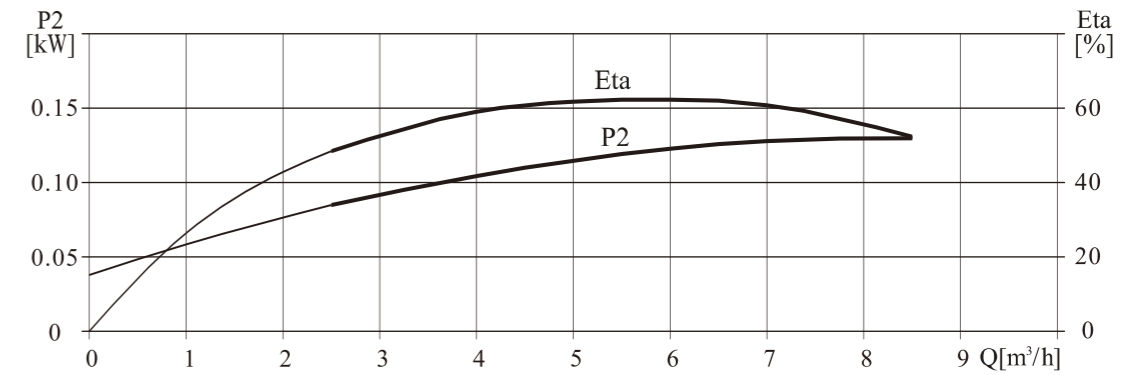
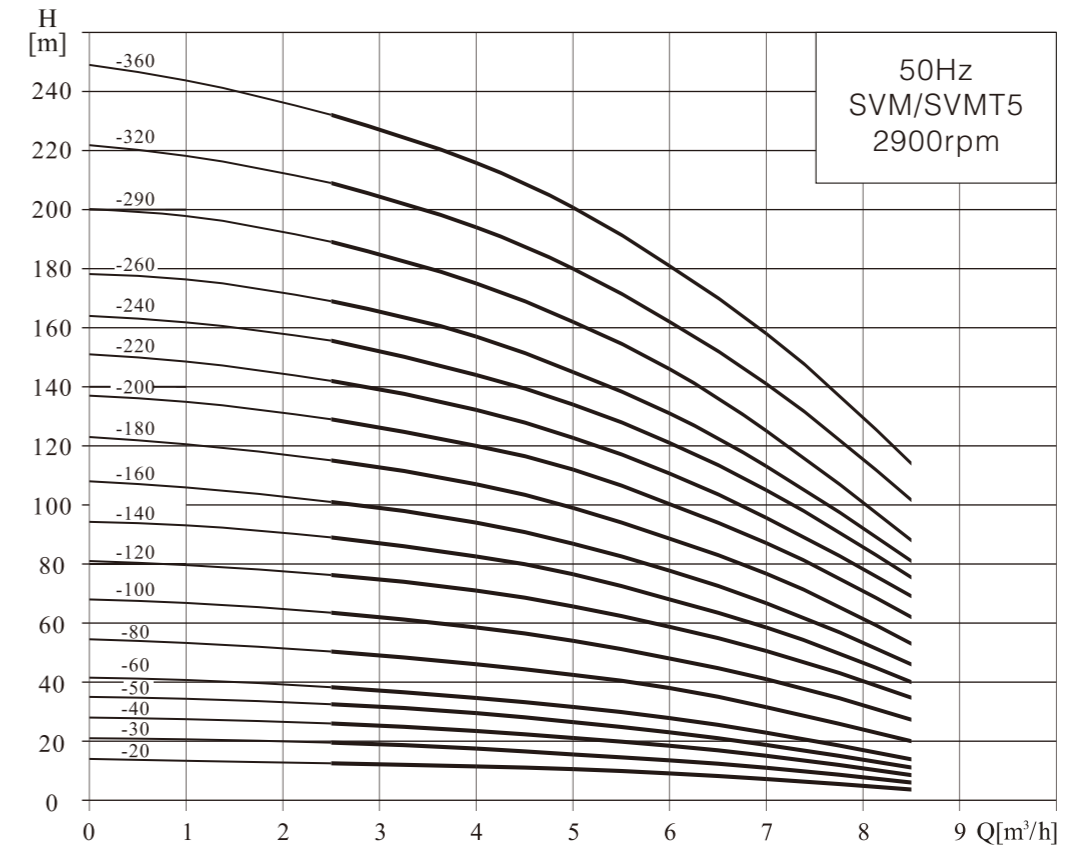

Installation dimensions and weight

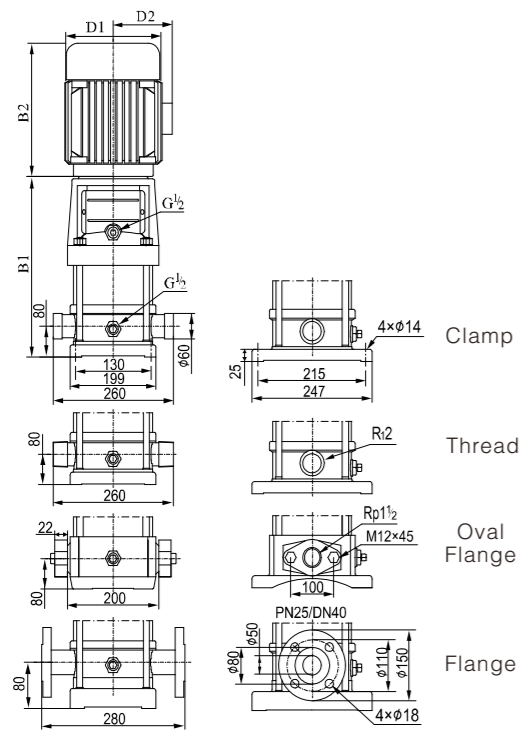

Model	Dimension (mm)					Weight (kg)
	B1	B2	B1+B2	D1	D2	
SVM(T)8-20	347	280	627	170	142	32
SVM(T)8-30	377	280	657	170	142	34
SVM(T)8-40	417	333	750	190	155	40
SVM(T)8-50	447	333	780	190	155	44
SVM(T)8-60	477	333	810	190	155	45
SVM(T)8-80	547	348	895	197	165	53
SVM(T)8-100	607	382	989	230	188	64
SVM(T)8-120	667	382	1049	230	188	66
SVM(T)8-140	747	435	1182	260	208	81
SVM(T)8-160	807	435	1242	260	208	84
SVM(T)8-180	867	435	1302	260	208	93
SVM(T)8-200	927	435	1362	260	208	94

Performance data

Model	Power		Q (m³/h)	H (m)																
	kW	Hp		5	6	7	8	9	10	11	12									
SVM(T)8-20	0.75	1	20	19.5	19	18	17	16	14	13										
SVM(T)8-30	1.1	1.5	30	29.5	28.5	27	25	24	21	19										
SVM(T)8-40	1.5	2	41	39.5	38	36	34	32	28	26										
SVM(T)8-50	2.2	3	52	50	48	45	42	40	36	32										
SVM(T)8-60	2.2	3	62	60	57	54	51	48	43	39										
SVM(T)8-80	3.0	4	83	80	77	73	69	65	58	52										
SVM(T)8-100	4.0	5.5	104	100	97	92	87	81	73	65										
SVM(T)8-120	4.0	5.5	124	120	116	111	104	92	87	78										
SVM(T)8-140	5.5	7.5	145	141	136	130	122	113	102	92										
SVM(T)8-160	5.5	7.5	166	161	156	148	139	130	118	106										
SVM(T)8-180	7.5	10	187	182	175	167	157	146	134	120										
SVM(T)8-200	7.5	10	208	202	195	186	175	163	150	135										

Performance curve

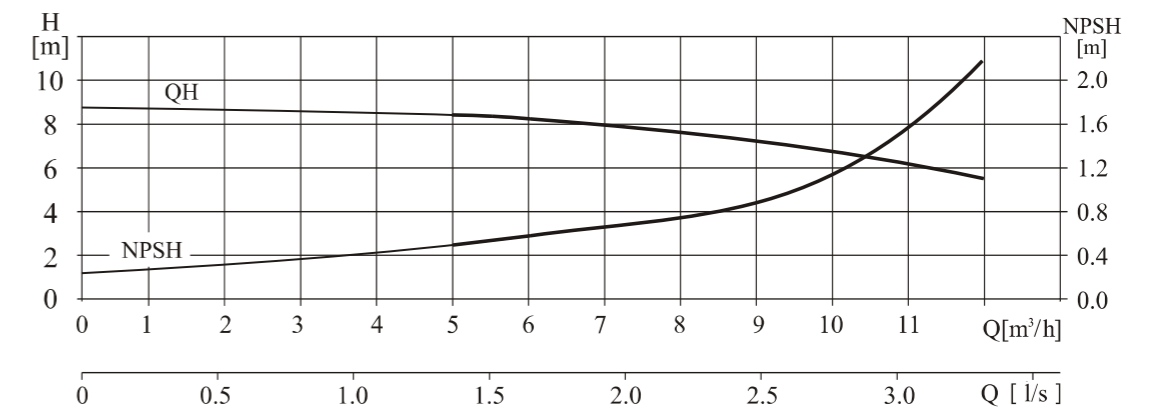
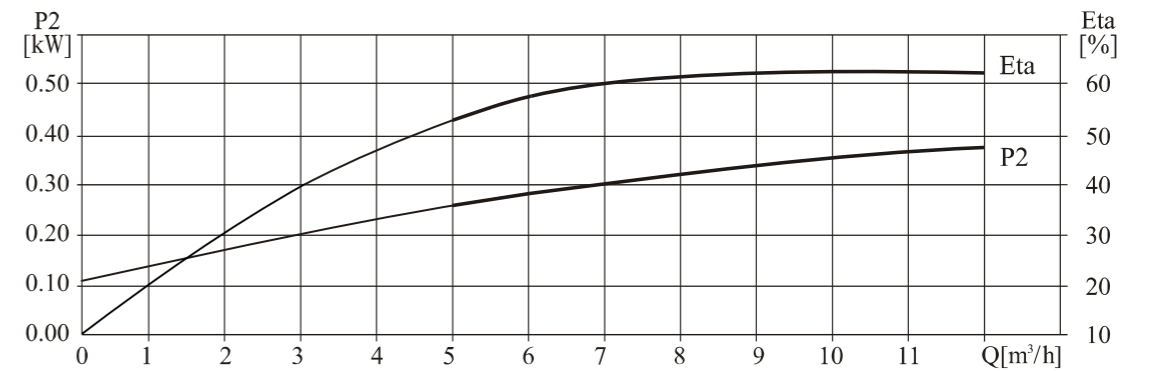
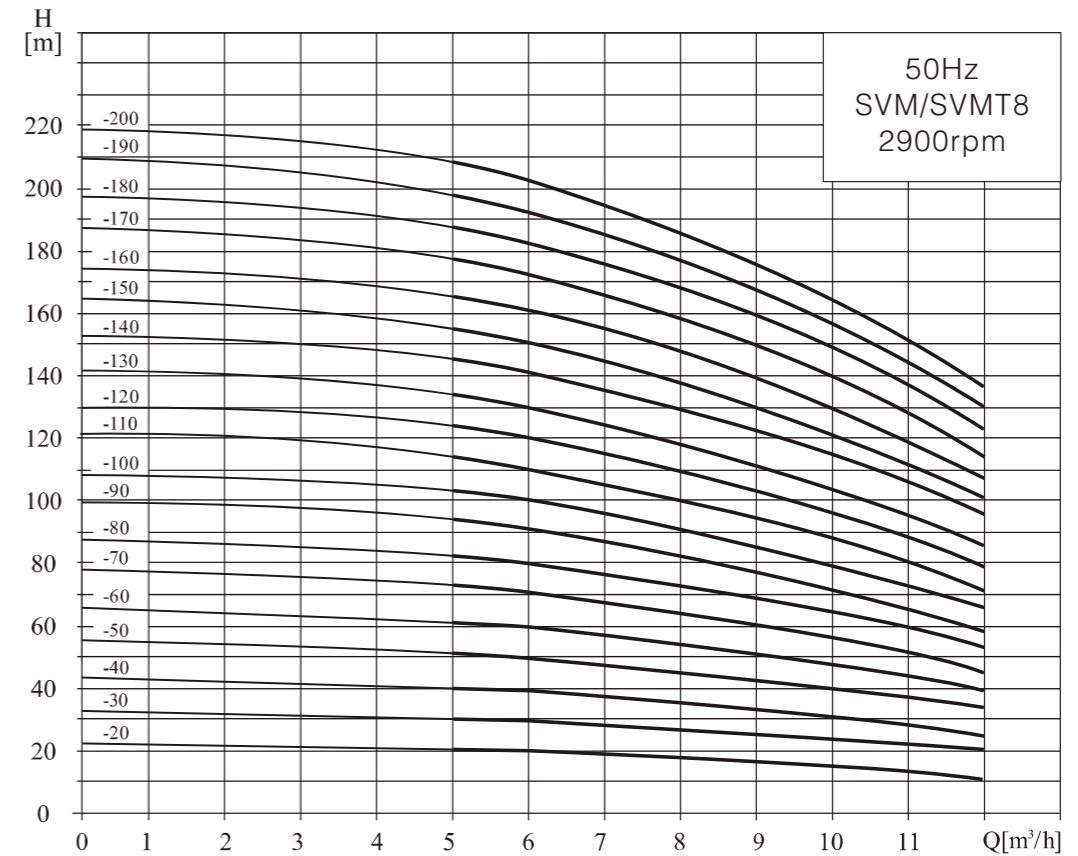

Installation dimensions and weight

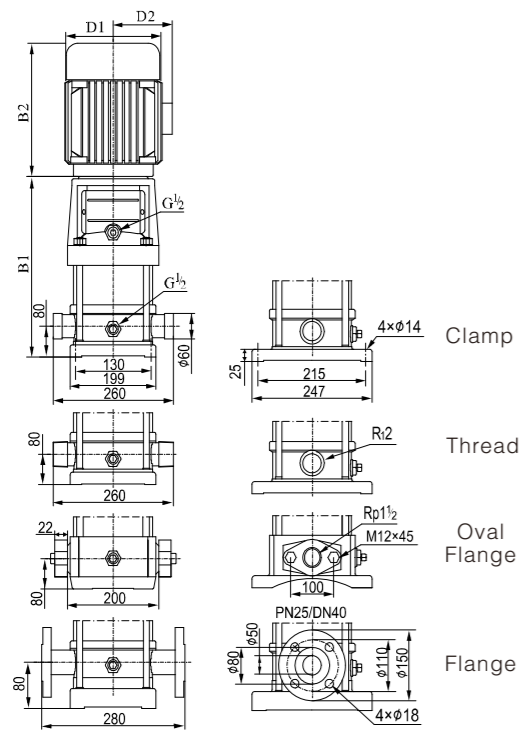

Model	Dimension (mm)					Weight (kg)
	B1	B2	B1+B2	D1	D2	
SVM(T)10-20	347	280	627	170	142	32
SVM(T)10-30	377	280	657	170	142	34
SVM(T) 10-40	417	333	750	190	155	40
SVM(T)10-50	447	333	780	190	155	44
SVM(T)10-60	477	333	810	190	155	45
SVM(T)10-70	517	348	865	197	165	52
SVM(T)10-80	547	348	895	197	165	53
SVM(T)10-90	577	348	925	197	165	54
SVM(T)10-100	607	382	989	230	185	64
SVM(T)10-120	667	382	1049	230	185	66
SVM(T) 10-140	747	435	1182	260	210	81
SVM(T)10-160	807	435	1242	260	210	82
SVM(T)10-180	867	435	1302	260	210	93
SVM(T)10-200	927	435	1362	260	210	94
SVM(T)10-220	987	435	1422	260	210	95

Performance data

Model	Power		Q (m³/h)	H (m)										
	kW	Hp		5	6	7	8	9	10	11	12	13		
SVM(T)10-20	0.75	1	18.5	17	16	14	13	12	10	8.5	7			
SVM(T)10-30	1.1	1.5	30	28.5	27.5	25.5	24.5	22	20	18	14.5			
SVM(T)10-40	1.5	2	40.5	39.5	38.5	36.5	34	31.5	28.5	25.5	21			
SVM(T)10-50	2.2	3	50	49	47.5	45.5	42.5	39.5	36	32	27			
SVM(T)10-60	2.2	3	60	59	57	55	51	47.5	43.5	39	33.5			
SVM(T)10-70	3.0	4	70.5	69	66.5	64	59.5	55.5	50.5	45.5	39			
SVM(T)10-80	3.0	4	81	79	77	74.5	69	64	58.5	53	44.5			
SVM(T)10-90	3.0	4	91	89	86.5	82.5	78	72	66.5	59.5	50			
SVM(T)10-100	4.0	5.5	101.5	99	96.5	92.5	87.5	81.5	74	67	57			
SVM(T)10-120	4.0	5.5	120.5	119	114	110	104	97	88.5	80	68			
SVM(T) 10-140	5.5	7.5	142	139	134.5	131	123	114	103.5	93.5	80			
SVM(T)10-160	5.5	7.5	162	159	154	148.5	139	130	119	107	91			
SVM(T)10-180	7.5	10	183	180	175	167	158	148	136	121	105			
SVM(T)10-200	7.5	10	203	200	195	186	176	165	151	134	118			
SVM(T)10-220	7.5	10	222	219	213	203	192	179	165	149	130			

Performance cruve

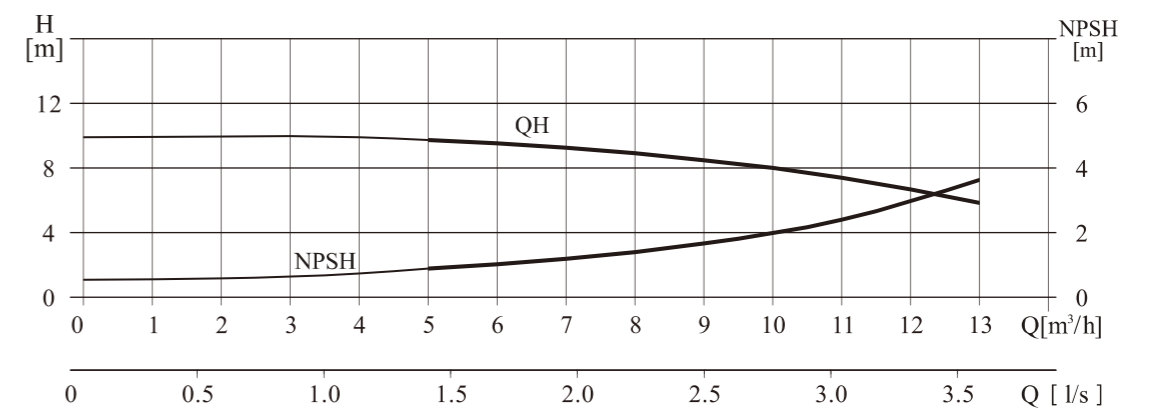
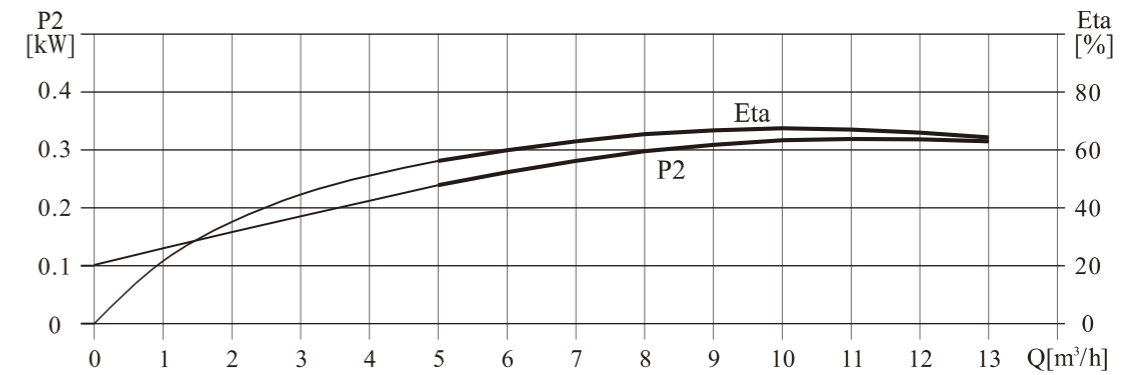
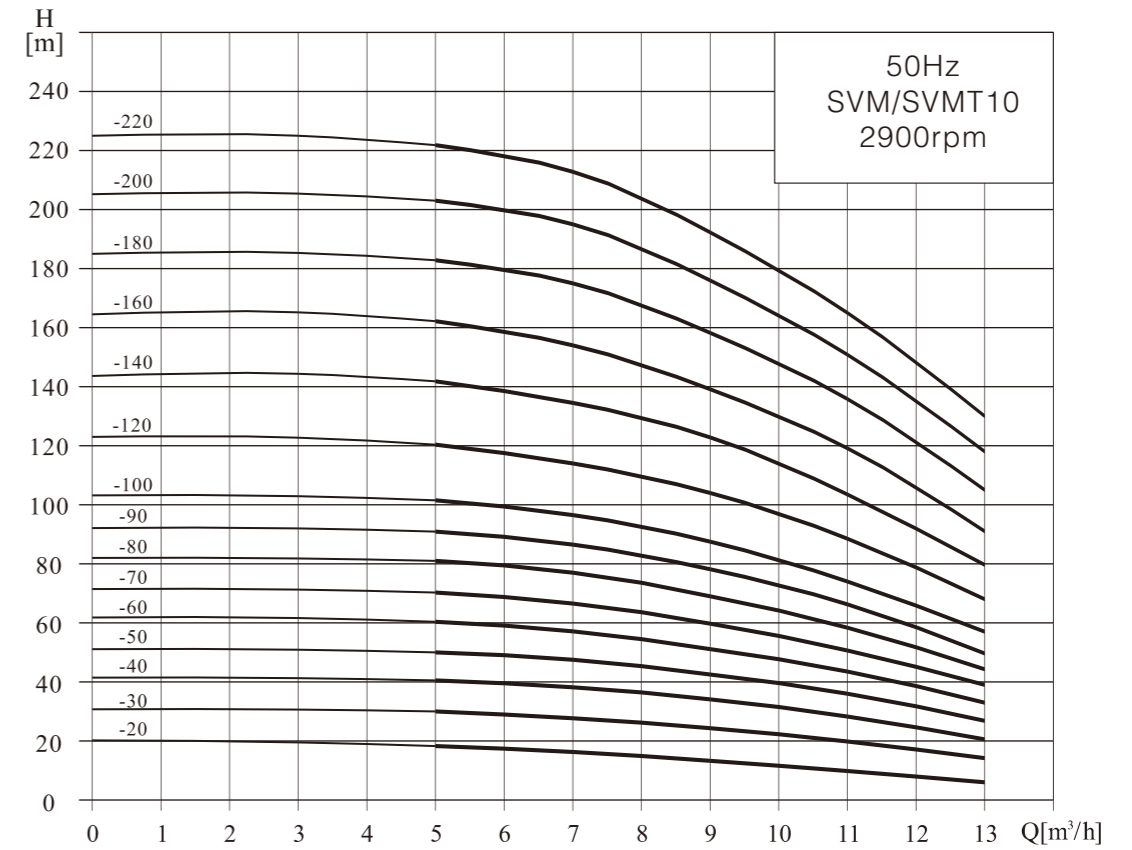

Installation dimensions and weight

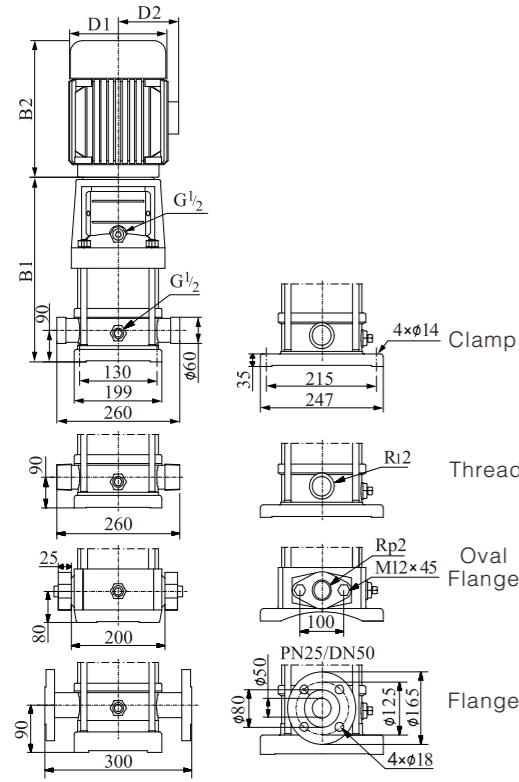

Model	Dimension (mm)					Weight (kg)
	B1	B2	B1+B2	D1	D2	
SVM(T)12-20	367	333	700	190	155	39
SVM(T)12-30	397	333	730	190	155	43
SVM(T)12-40	437	348	785	197	165	51
SVM(T)12-50	467	348	815	197	165	53
SVM(T)12-60	497	382	879	230	188	61
SVM(T)12-70	547	435	982	260	208	73
SVM(T)12-80	577	435	1012	260	208	74
SVM(T)12-90	607	435	1042	260	208	76
SVM(T)12-100	637	435	1072	260	208	83
SVM(T)12-120	697	435	1132	260	208	87
SVM(T)12-140	757	580	1425	350	260	158
SVM(T)12-160	905	580	1485	350	260	161
SVM(T)12-180	965	580	1545	350	260	164

Performance data

Model	Power		Q (m³/h)	H (m)											
	kW	Hp		7	8	9	10	11	12	13	14	15	16		
SVM(T)12-20	1.5	2	23.5	23	22.5	22	21	20	18.5	17	15.5	14			
SVM(T)12-30	2.2	3	35.5	35	34	33	31.5	30	28	26	23.5	21			
SVM(T)12-40	3	4	47	46	45	44	42	40	37	34	31	28			
SVM(T)12-50	3	4	59.5	58	56.5	55	52.5	50	46.5	43	39	35			
SVM(T)12-60	4	5.5	71.5	70	68	66	63	60	56	52	47	42			
SVM(T)12-70	5.5	7.5	83.5	82	79.5	77	73.5	70	65.5	61	55	49			
SVM(T)12-80	5.5	7.5	95.5	94	91	88	84	80	75	70	63	56			
SVM(T)12-90	5.5	7.5	108	106	103	100	95.5	91	85	79	71.5	64			
SVM(T)12-100	7.5	10	120	118	114.5	111	106	101	94.5	88	80	72			
SVM(T)12-120	7.5	10	143.5	141	137	133	127	121	113.5	106	96	86			
SVM(T)12-140	11	15	168	165	160	155	148	141	132.5	124	112	100			
SVM(T)12-160	11	15	192.5	189	183.5	178	170	162	152	142	128.5	115			
SVM(T)12-180	11	15	217	213	207.5	202	192.5	183	171.5	160	145	130			

Performance cruve

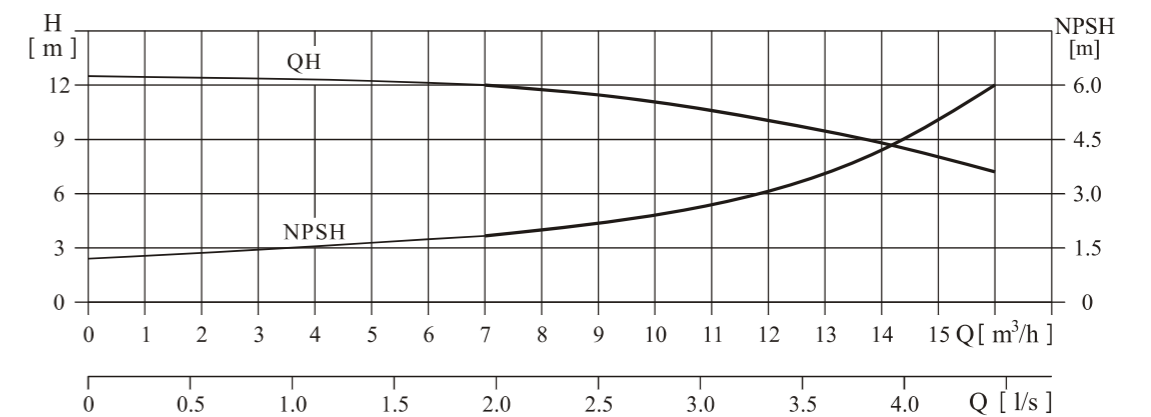
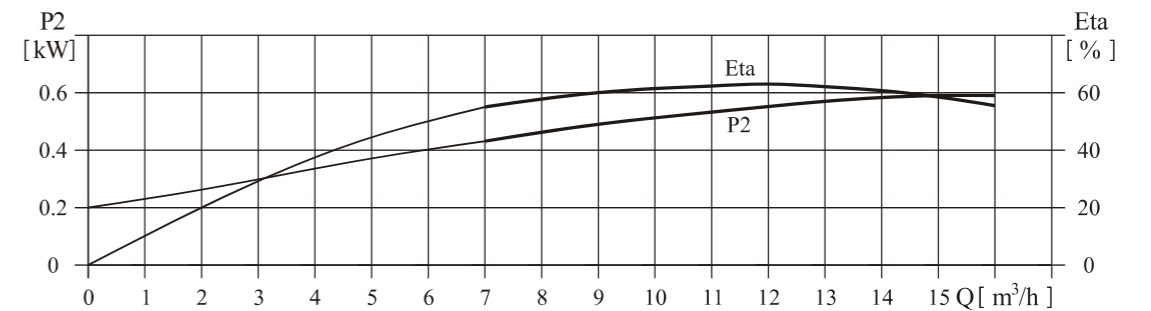
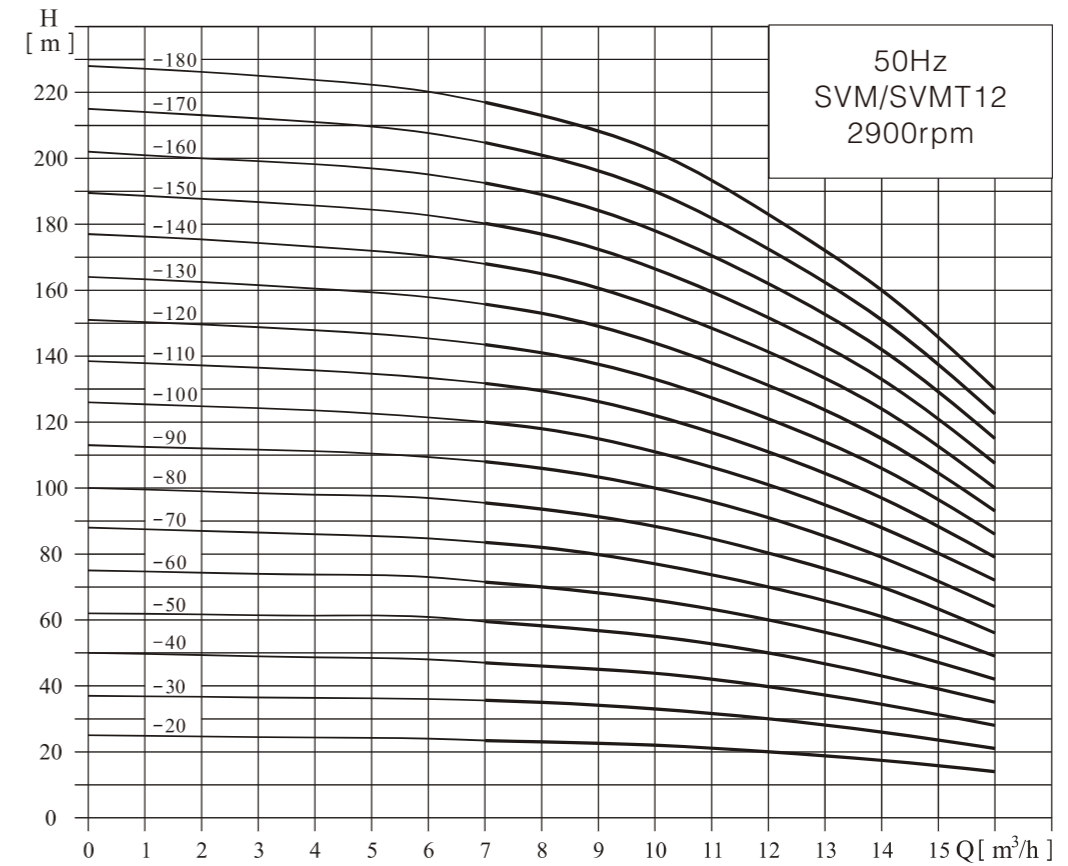

Installation dimensions and weight

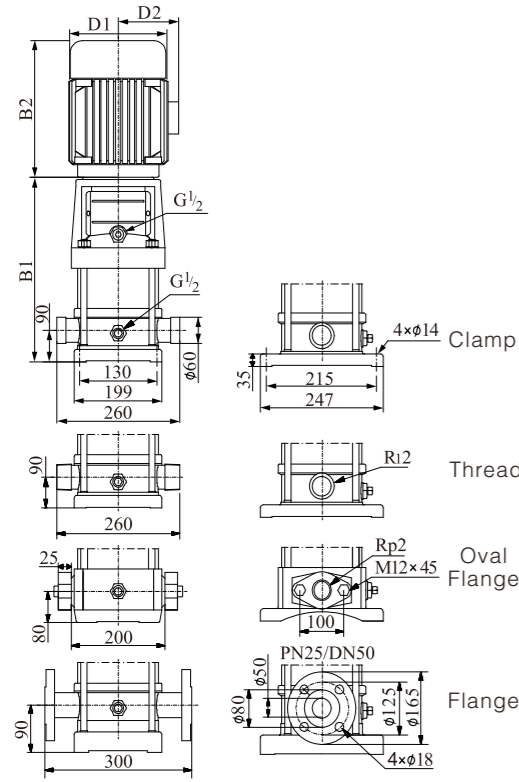

Model	Dimension (mm)					Weight (kg)
	B1	B2	B1+B2	D1	D2	
SVM(T)15-10	352	280	632	170	142	33
SVM(T)15-20	397	333	730	190	155	42
SVM(T)15-30	452	348	800	197	165	50
SVM(T)15-40	497	382	879	230	185	59
SVM(T)15-50	542	382	924	230	185	60
SVM(T)15-60	607	435	1042	260	210	77
SVM(T)15-70	652	435	1087	260	210	78
SVM(T)15-80	697	435	1132	260	210	86
SVM(T)15-90	742	435	1177	260	210	87
SVM(T) 15-100	875	580	1455	350	260	160
SVM(T)15-120	965	580	1545	350	260	161
SVM(T)15-140	1055	580	1635	350	260	162
SVM(T) 15-170	1190	580	1770	350	260	179

Performance data

Model	Power		Q (m³/h)	H (m)										
	kW	Hp		8	10	12	14	15	16	18	20	23		
SVM(T)15-10	1.1	1.5	13	12	11.5	10.5	10	9	7.5	6	4.5			
SVM(T)15-20	2.2	3	26	25	24	23	22	20.5	18	16	13			
SVM(T)15-30	3.0	4	39.5	38.5	37.5	35.5	34.5	33.5	30.5	27	21			
SVM(T)15-40	4.0	5.5	53	51.5	50	47.5	46	44.5	41	36.5	29			
SVM(T)15-50	4.0	5.5	67	64.5	62.5	60	58	55.5	52	46	37			
SVM(T)15-60	5.5	7.5	80.5	78	76	73	70.5	68	63.5	57	46.5			
SVM(T)15-70	5.5	7.5	94	92	89.5	86	83.5	81	75.5	68.5	56.5			
SVM(T)15-80	7.5	10	107.5	106	102.5	98.5	96	93	86.5	78	64.5			
SVM(T)15-90	7.5	10	120	118	114.5	110	107	105	97	88	72			
SVM(T)15-100	11	15	134	132	128	123	120	116.5	108.5	98.5	82.5			
SVM(T)15-120	11	15	161	158	154	148	144	139	130	119	99			
SVM(T)15-140	11	15	186	183	178	172	167	162	152	139	116			
SVM(T)15-170	15	20	227	224	217	210	203	196	185	167	140			

Performance cruve

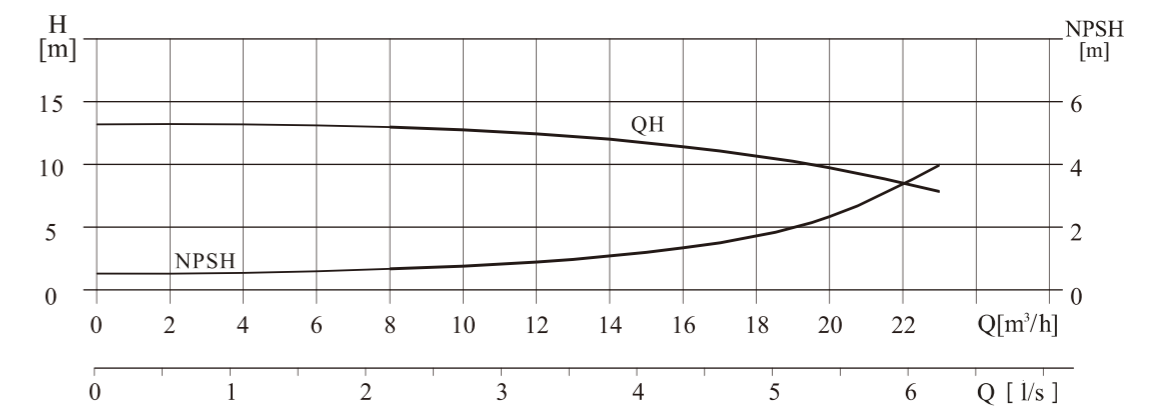
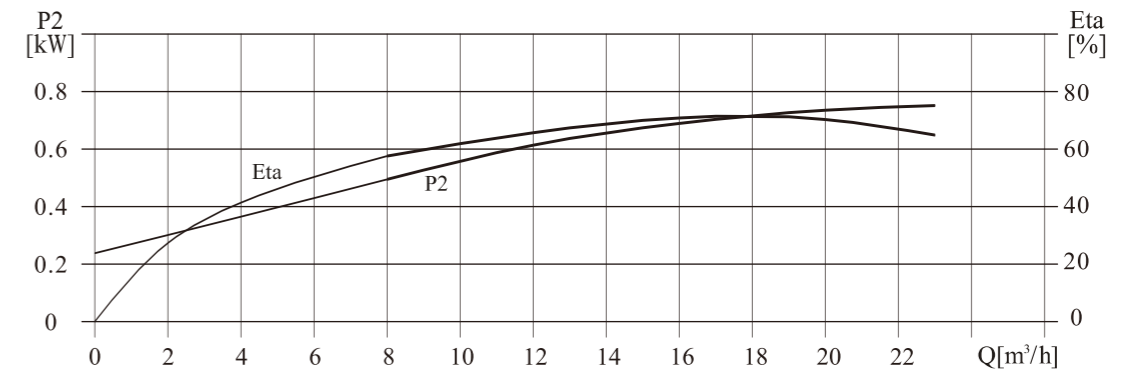
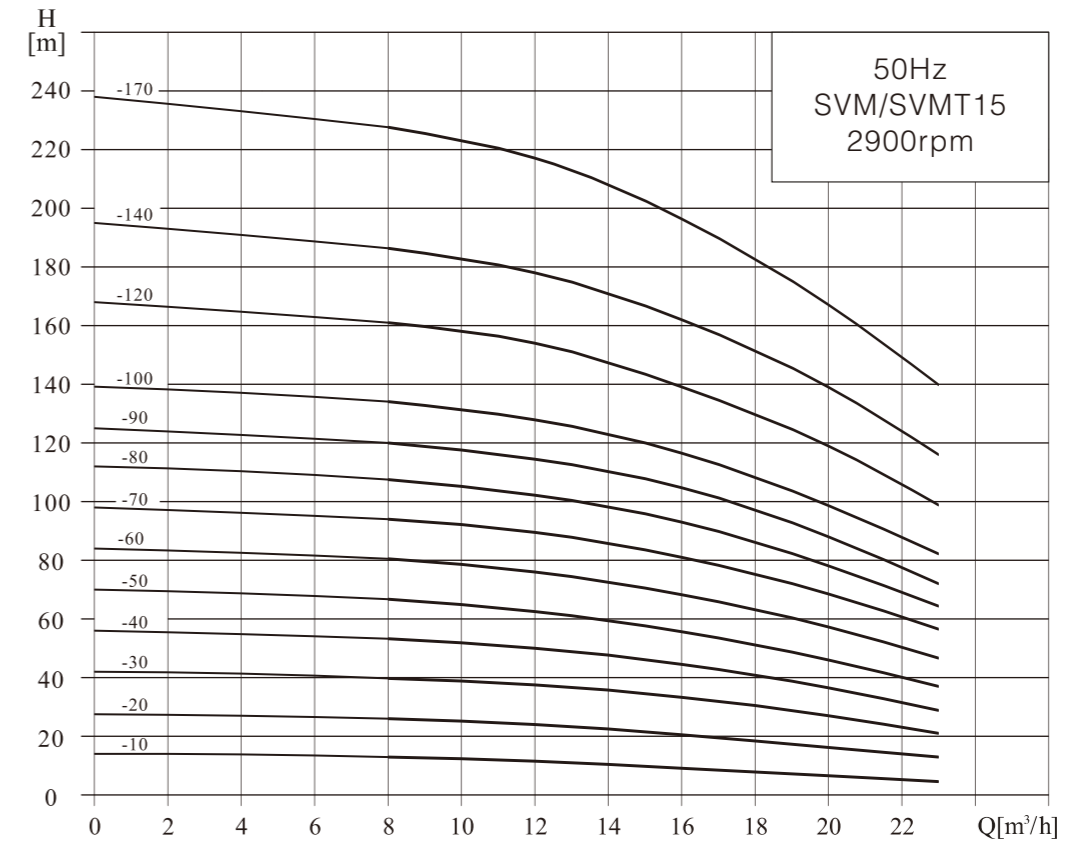

Installation dimensions and weight

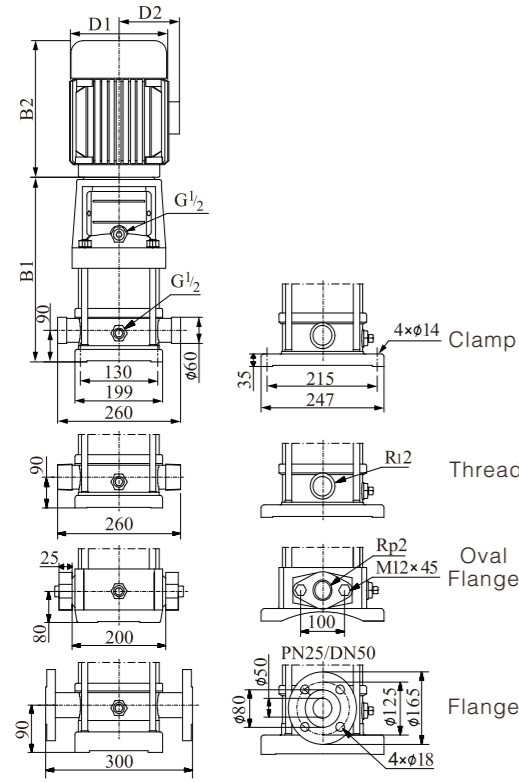

Model	Dimension (mm)					Weight (kg)
	B1	B2	B1+B2	D1	D2	
SVM(T)16-20	397	333	730	190	155	42
SVM(T)16-30	452	348	800	197	165	50
SVM(T)16-40	497	382	879	230	188	59
SVM(T)16-50	562	435	997	260	208	76
SVM(T)16-60	607	435	1042	260	208	77
SVM(T)16-70	652	435	1087	260	208	84
SVM(T)16-80	697	435	1132	260	208	86
SVM(T)16-100	787	580	1455	350	260	106
SVM(T)16-120	965	580	1545	350	260	161
SVM(T)16-140	1055	580	1635	350	260	174
SVM(T)16-160	1145	580	1725	350	260	178

Performance data

Model	Power		Q (m³/h)	H (m)																
	kW	Hp		8	10	12	14	16	18	20	22									
SVM(T)16-20	2.2	3	H (m)	27	26	25	24	22	21	19	16									
SVM(T)16-30	3.0	4		41	40	38	37	34	32	29	25									
SVM(T)16-40	4.0	5.5		54	53	52	49	46	43	38	34									
SVM(T)16-50	5.5	7.5		68	67	65	62	58	54	48	43									
SVM(T)16-60	5.5	7.5		82	80	78	74	70	64	58	52									
SVM(T)16-70	7.5	10		96	95	91	87	82	76	68	61									
SVM(T)16-80	7.5	10		110	108	104	99	94	86	77	70									
SVM(T)16-100	11	15		138	136	131	125	118	109	97	87									
SVM(T)16-120	11	15		166	162	157	150	141	130	116	105									
SVM(T)16-140	15	20		194	190	184	175	166	152	136	122									
SVM(T)16-160	15	20	222	217	210	200	189	174	156	140										

Performance cruve

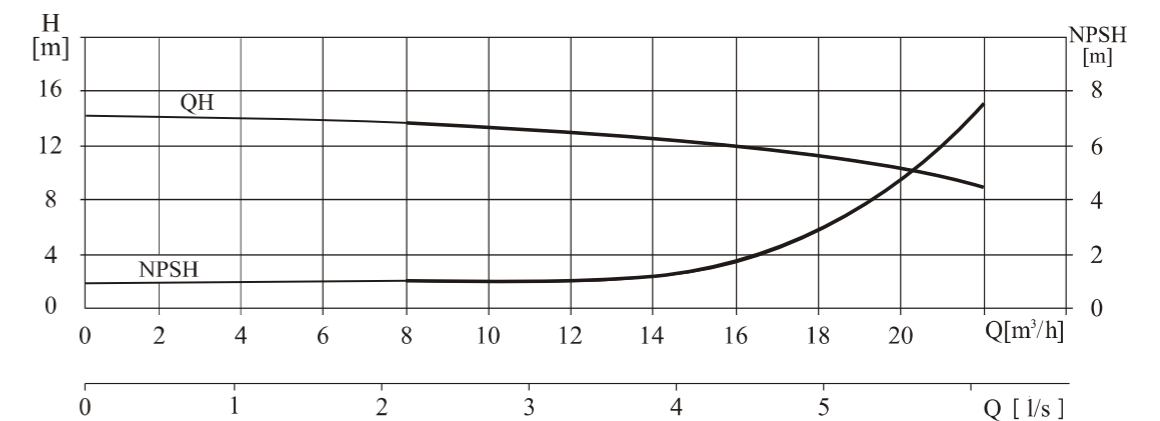
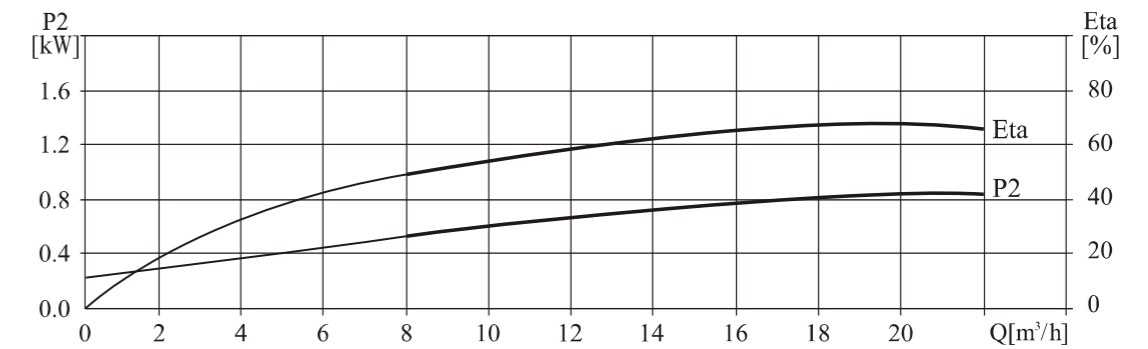
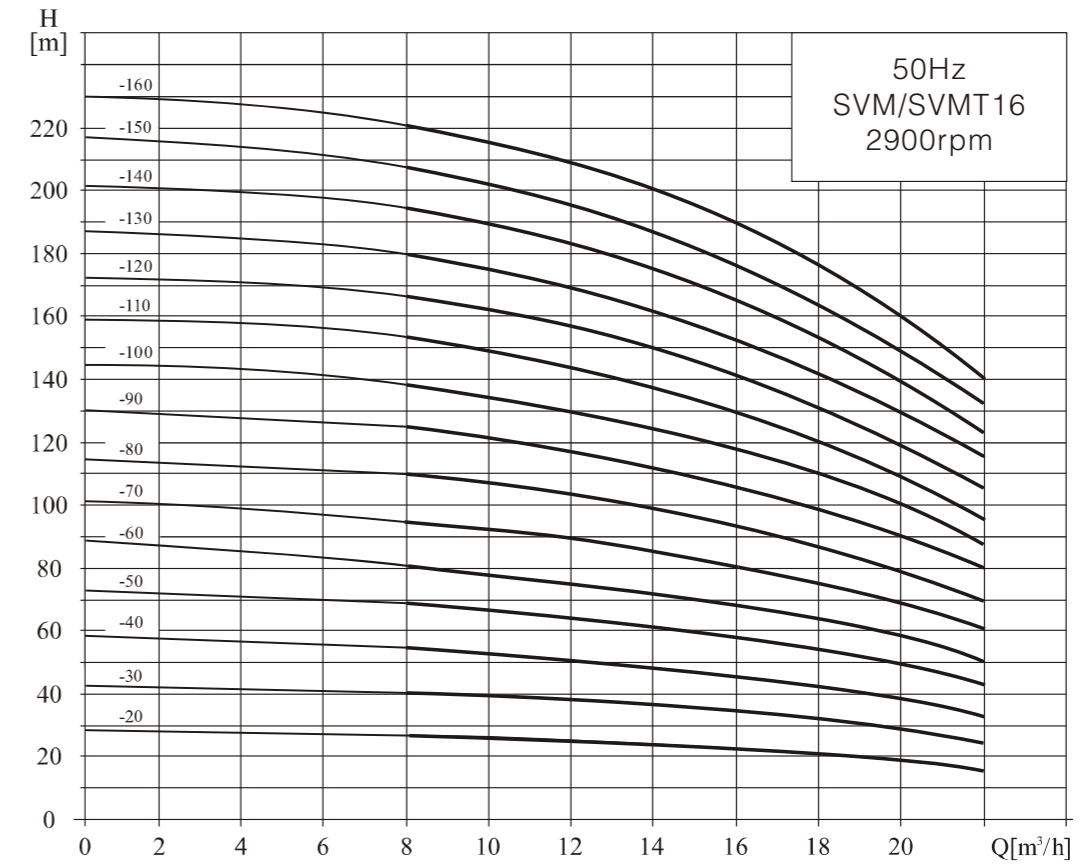

Installation dimensions and weight

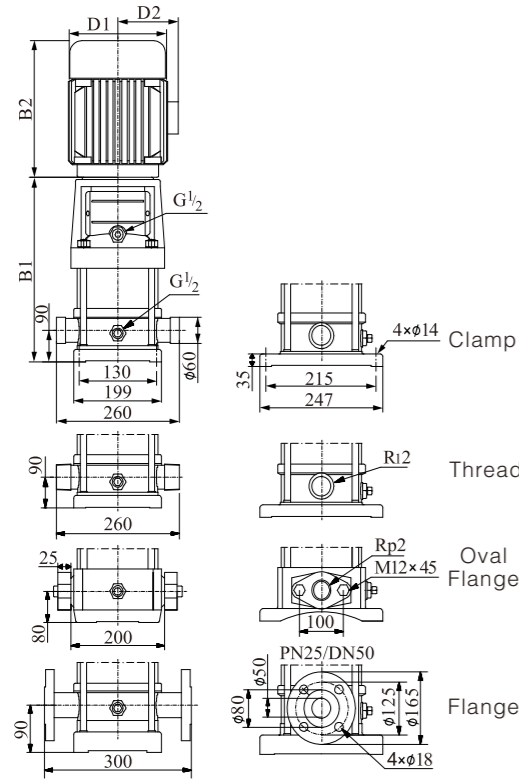

Model	Dimension (mm)					Weight (kg)
	B1	B2	B1+B2	D1	D2	
SVM(T)20-10	387	280	667	170	142	33
SVM(T)20-20	397	333	730	190	155	42
SVM(T)20-30	452	382	834	230	188	58
SVM(T)20-40	517	435	952	260	208	74
SVM(T)20-50	562	435	997	260	208	76
SVM(T)20-60	607	435	1042	260	208	82
SVM(T)20-70	652	435	1087	260	208	84
SVM(T)20-80	697	580	1365	350	260	153
SVM(T)20-100	875	580	1455	350	260	157
SVM(T)20-120	965	580	1545	350	260	170
SVM(T)20-140	1055	580	1635	350	260	172
SVM(T)20-170	1190	610	1800	350	260	195

Performance data

Model	Power		Q (m³/h)	H (m)											
	kW	Hp		10	12	14	16	18	20	22	24	26	28		
SVM(T)20-10	1.1	1.5	13.5	13	12.5	12	11	10	9	8	7	6			
SVM(T)20-20	2.2	3	27	26.5	26	25	24	23	22	20	18	15			
SVM(T)20-30	4.0	5.5	40	39.5	39	38	37	35	33	30	27	24			
SVM(T)20-40	5.5	5.5	54	53	52	51	49	47	44	41	37	33			
SVM(T)20-50	5.5	5.5	67	66	64	62	60	58	55	50	45	40			
SVM(T)20-60	7.5	10	81	79	77	75	73	70	66	61	55	49			
SVM(T)20-70	7.5	10	95	93	91	89	86	82	77	71	65	58			
SVM(T)20-80	11	15	109	107	105	102	99	94	89	82	75	67			
SVM(T)20-100	11	15	136	134	131	128	124	118	111	103	95	85			
SVM(T)20-120	15	20	164	162	158	154	149	142	133	124	114	102			
SVM(T)20-140	15	20	192	189	185	180	174	166	156	145	133	119			
SVM(T)20-170	18.5	25	234	230	225	219	212	202	190	177	162	145			

Performance cruve

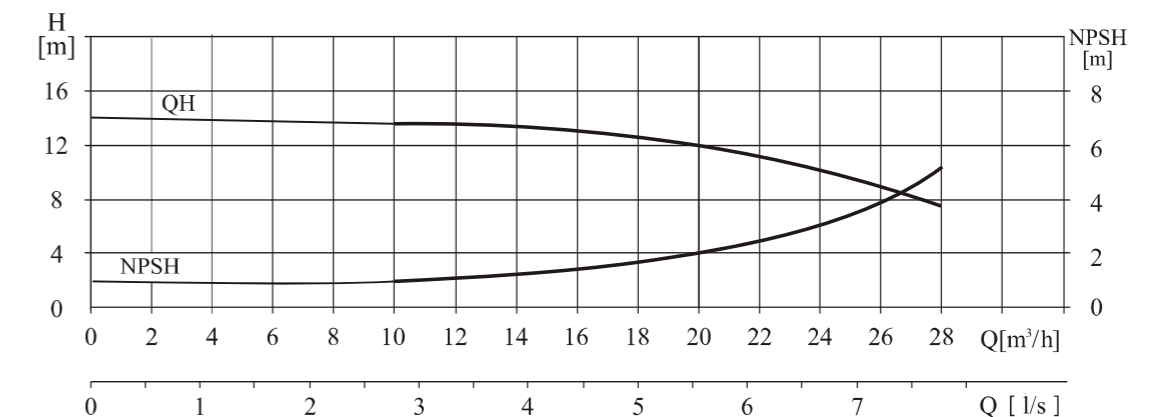
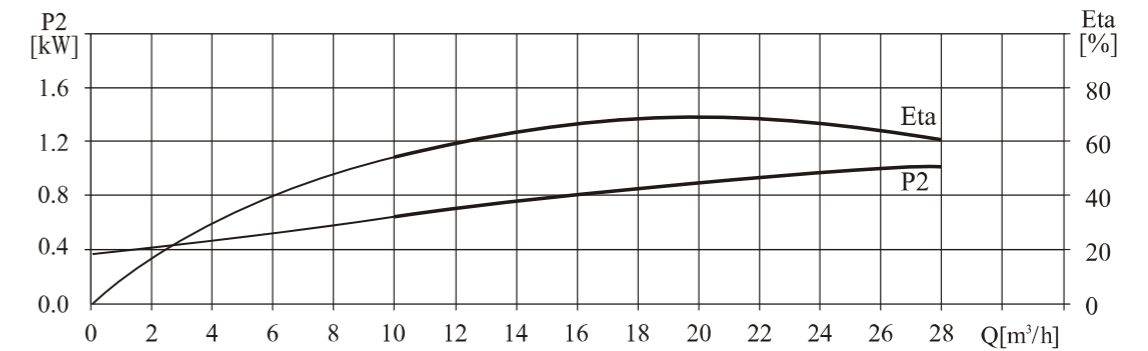
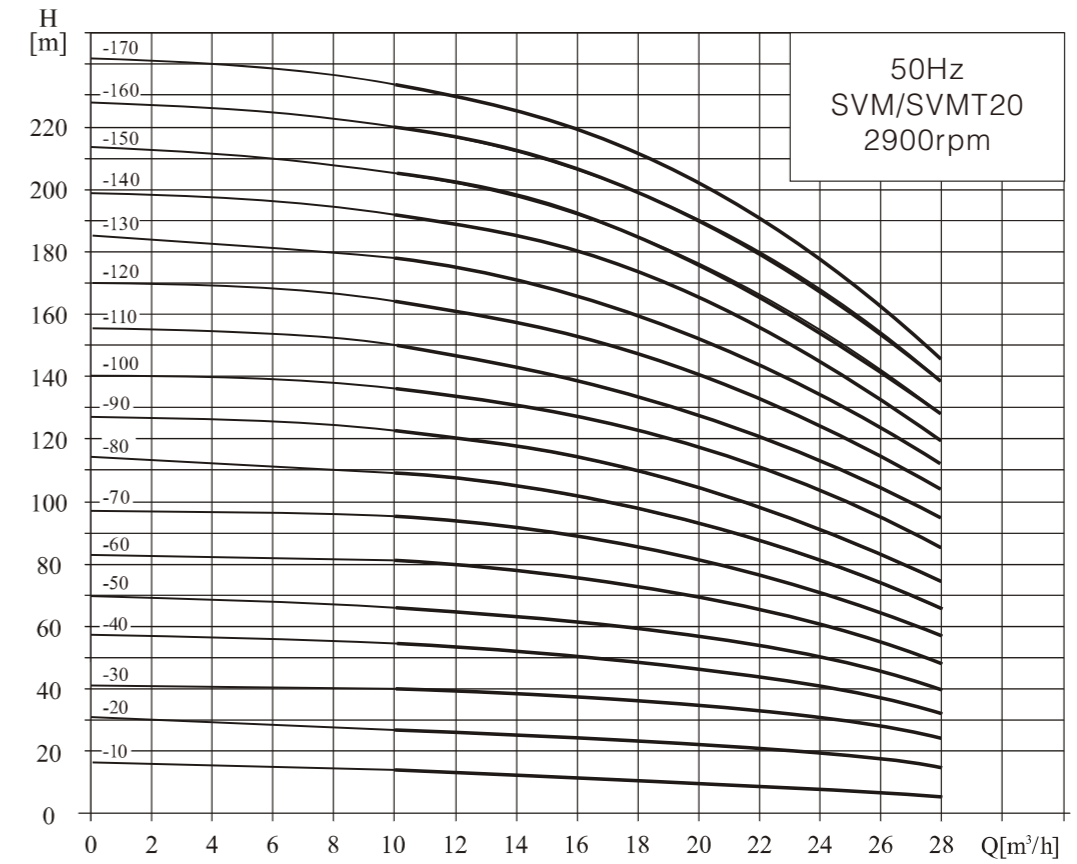

Installation dimensions and weight

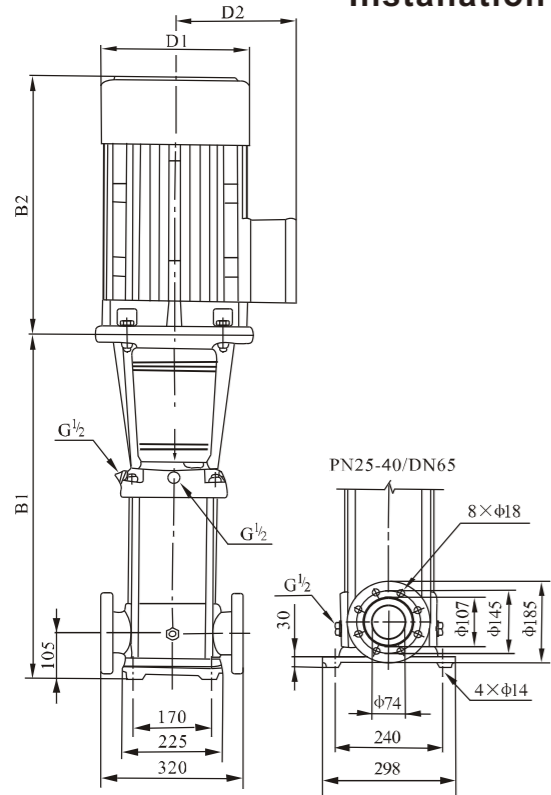

Model	Dimension (mm)					Weight (kg)
	B1	B2	B1+B2	D1	D2	
SVM(T)32-10-1/32-10	505	333	838	190	155	67
SVM(T)32-20-2/32-20	575	370	945	230	185	83
SVM(T)32-30-2/32-30	645	435	1080	260	208	100
SVM(T)32-40-2/32-40	715	435	1150	260	208	109
SVM(T)32-50-2/32-50	890	580	1470	350	260	181
SVM(T)32-60-2/32-60	960	580	1540	350	260	185
SVM(T)32-70-2/32-70	1030	580	1610	350	260	199
SVM(T)32-80-2/32-80	1100	580	1680	350	260	203
SVM(T)32-90-2/32-90	1170	610	1780	350	260	222
SVM(T)32-100-2/32-100	1240	610	1850	350	260	227
SVM(T)32-110-2/32-110	1310	645	1955	360	285	272
SVM(T)32-120-2/32-120	1380	645	2025	360	285	276
SVM(T)32-130-2/32-130	1450	705	2155	400	310	337
SVM(T)32-140-2/32-140	1520	705	2225	400	310	341
SVM(T)32-150-2/32-150	1590	705	2295	400	310	345
SVM(T)32-160-2/32-160	1660	705	2365	400	310	350

Performance data

Model	Power		Q (m³/h)	H (m)								Model	Power		Q (m³/h)	H (m)							
	kW	Hp		16	20	24	28	32	36	40	16		20	24		28	32	36	40				
SVM(T)32-10-1	1.5	2	14	13	12	11	9	7	4	SVM(T)32-90-2	18.5	25	154	148	140	129	117	102	82				
SVM(T)32-10	2.2	3	18	17	15	14	13	11	8	SVM(T)32-90	18.5	25	162	156	147	136	124	109	88				
SVM(T)32-20-2	3.0	4	29	28	26	23	20	16	11	SVM(T)32-100-2	18.5	25	175	166	157	146	131	115	91				
SVM(T)32-20	4.0	5.5	36	34	32	29	27	23	18	SVM(T)32-100	18.5	25	182	173	164	152	138	122	98				
SVM(T)32-30-2	5.5	7.5	47	44	41	38	33	28	21	SVM(T)32-110-2	22	30	193	184	173	164	146	128	102				
SVM(T)32-30	5.5	7.5	54	51	48	44	40	35	27	SVM(T)32-110	22	30	200	191	180	168	153	135	109				
SVM(T)32-40-2	7.5	10	65	62	58	53	46	40	30	SVM(T)32-120-2	22	30	211	201	189	178	160	140	113				
SVM(T)32-40	7.5	10	72	69	65	59	53	47	37	SVM(T)32-120	22	30	218	208	196	184	167	147	120				
SVM(T)32-50-2	11	15	83	79	74	68	60	52	41	SVM(T)32-130-2	30	40	230	218	206	193	174	153	124				
SVM(T)32-50	11	15	90	86	81	74	67	59	47	SVM(T)32-130	30	40	237	225	213	200	181	160	131				
SVM(T)32-60-2	11	15	101	97	90	83	74	65	51	SVM(T)32-140-2	30	40	247	235	222	210	189	165	135				
SVM(T)32-60	11	15	108	104	97	90	81	72	57	SVM(T)32-140	30	40	255	242	229	216	196	172	142				
SVM(T)32-70-2	15	20	119	114	107	98	88	78	60	SVM(T)32-150-2	30	40	266	253	239	224	203	178	145				
SVM(T)32-70	15	20	126	121	113	105	95	85	67	SVM(T)32-150	30	40	274	260	246	231	210	185	152				
SVM(T)32-80-2	15	20	136	131	123	114	102	90	71	SVM(T)32-160-2	30	40	284	270	255	240	218	190	156				
SVM(T)32-80	15	20	144	138	130	120	109	97	77	SVM(T)32-160	30	40	292	277	262	246	225	197	163				

Performance curve

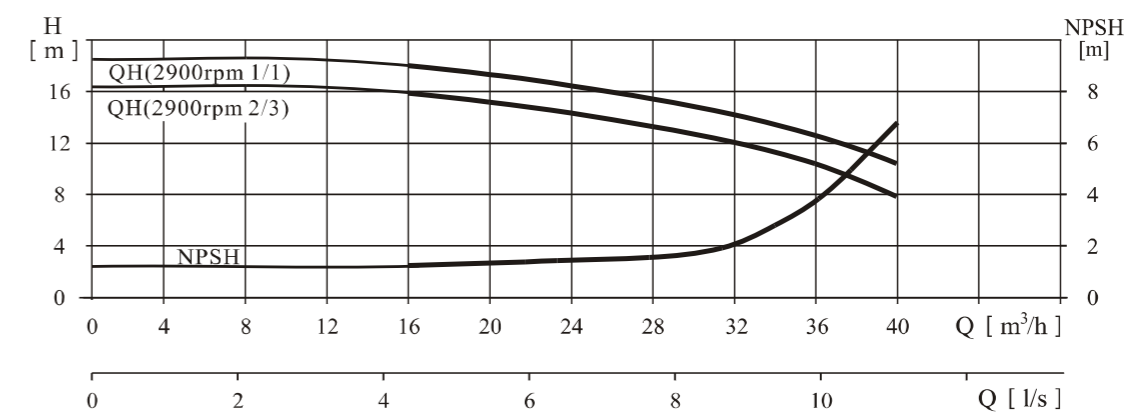
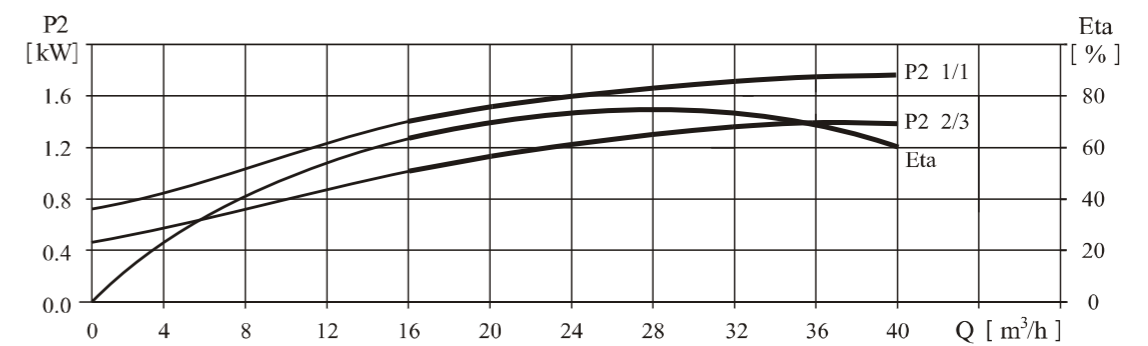
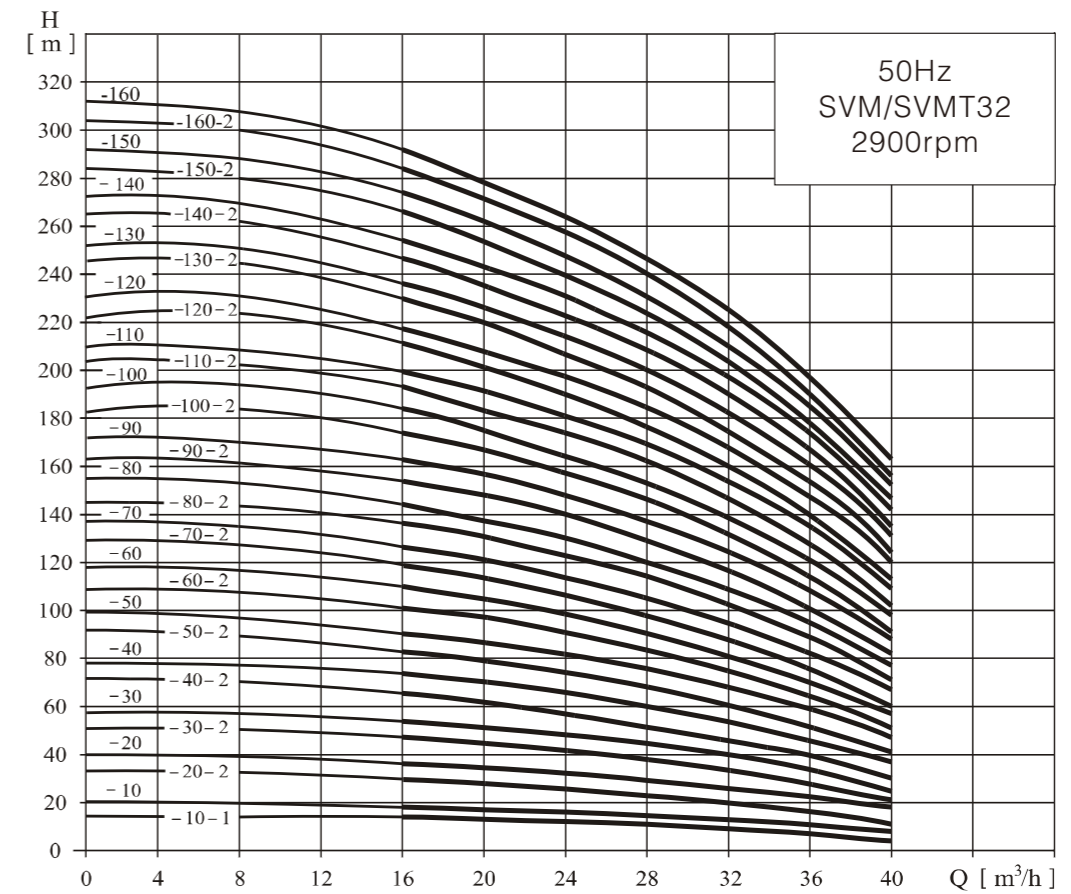

Installation dimensions and weight

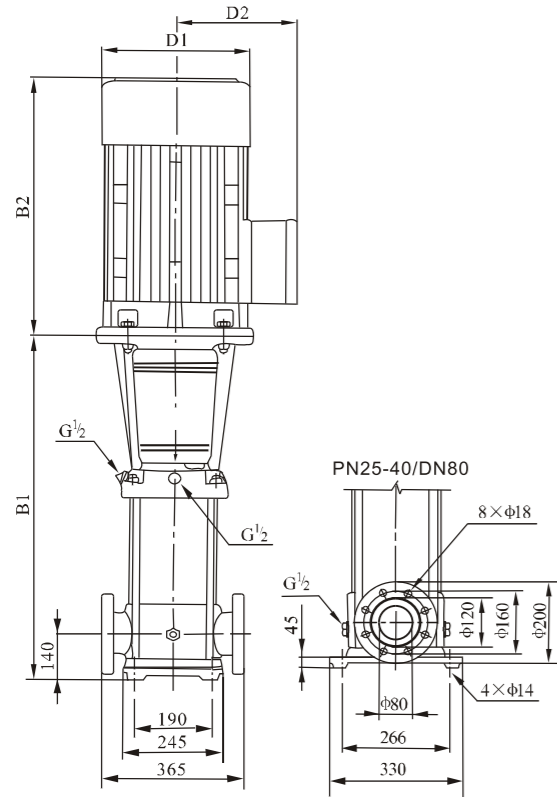

Model	Dimension (mm)					Weight (kg)
	B1	B2	B1+B2	D1	D2	
SVM(T)45-10-1	561	370	931	230	185	89
SVM(T)45-10						
SVM(T)45-20-2	641	435	1076	260	208	108
SVM(T)45-20						
SVM(T)45-30-2	826	580	1406	350	260	183
SVM(T)45-30						
SVM(T)45-40-2	906	580	1486	350	260	197
SVM(T)45-40						
SVM(T)45-50-2	986	610	1596	350	260	221
SVM(T)45-50						
SVM(T)45-60-2	1066	645	1711	360	285	261
SVM(T)45-60						
SVM(T)45-70-2	1146	705	1851	400	310	320
SVM(T)45-70						
SVM(T)45-80-2	1226	705	1931	400	310	324
SVM(T)45-80						
SVM(T)45-90-2	1306	705	2011	400	310	328/352
SVM(T)45-90						
SVM(T)45-100-2	1386	705	2091	400	310	355
SVM(T)45-100						
SVM(T)45-110-2	1466	740	2206	450	345	426
SVM(T)45-110						
SVM(T)45-120-2	1546	740	2286	450	345	432
SVM(T)45-120						
SVM(T)45-130-2	1626	740	2366	450	345	438

Performance data

Model	Power		Q (m³/h)	H (m)											
	kW	Hp		25	30	35	40	45	50	55					
SVM(T)45-10-1	3.0	4	20	19	18	17	15	13	11						
SVM(T)45-10	4.0	5.5	24	23	22	21	19	18	16						
SVM(T)45-20-2	5.5	7.5	40	38	36	33	30	27	23						
SVM(T)45-20	7.5	10	48	46	44	42	39	35	31						
SVM(T)45-30-2	11	15	63	61	58	54	50	44	38						
SVM(T)45-30	11	15	71	69	66	63	58	53	47						
SVM(T)45-40-2	15	20	87	84	80	75	69	62	54						
SVM(T)45-40	15	20	95	92	88	84	78	71	62						
SVM(T)45-50-2	18.5	25	111	107	102	96	88	80	69						
SVM(T)45-50	18.5	25	119	115	110	105	97	88	78						
SVM(T)45-60-2	22	30	135	130	124	117	108	97	85						
SVM(T)45-60	22	30	143	138	132	125	116	106	93						
SVM(T)45-70-2	30	30	158	152	146	138	127	115	100						
SVM(T)45-70	30	40	166	161	154	146	135	124	109						
SVM(T)45-80-2	30	40	182	175	168	159	146	133	116						
SVM(T)45-80	30	40	190	184	176	167	154	141	124						
SVM(T)45-90-2	30	40	205	198	190	180	166	150	132						
SVM(T)45-90	37	50	214	207	198	188	174	159	140						
SVM(T)45-100-2	37	50	230	221	212	200	185	168	147						
SVM(T)45-100	37	50	238	230	220	209	193	177	155						
SVM(T)45-110-2	45	60	255	246	236	223	206	188	165						
SVM(T)45-110	45	60	263	255	244	232	214	196	173						
SVM(T)45-120-2	45	60	280	270	259	245	226	206	181						
SVM(T)45-120	45	60	289	280	268	255	236	216	190						
SVM(T)45-130-2	45	60	305	294	282	267	247	225	198						

Performance cruve

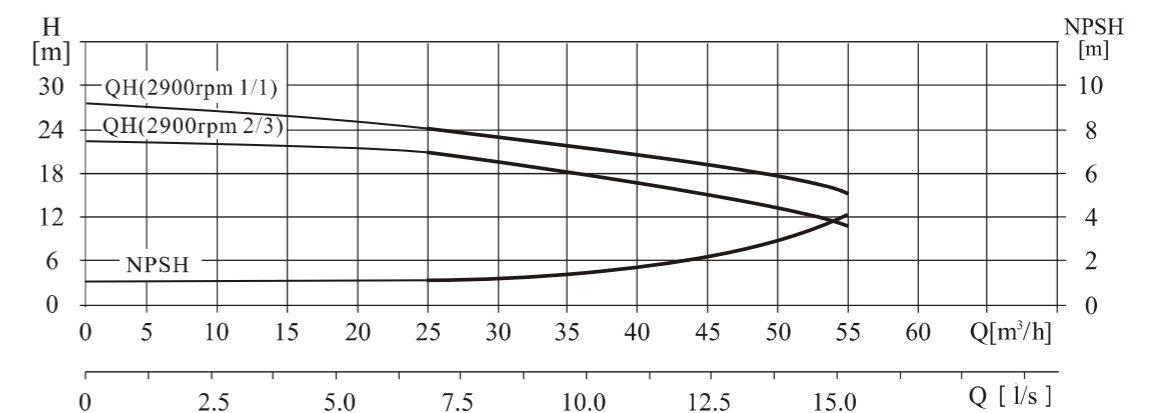
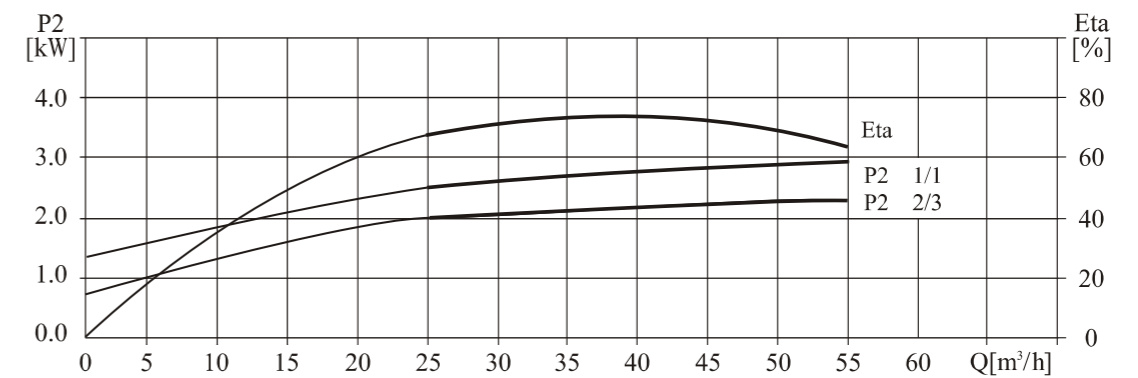
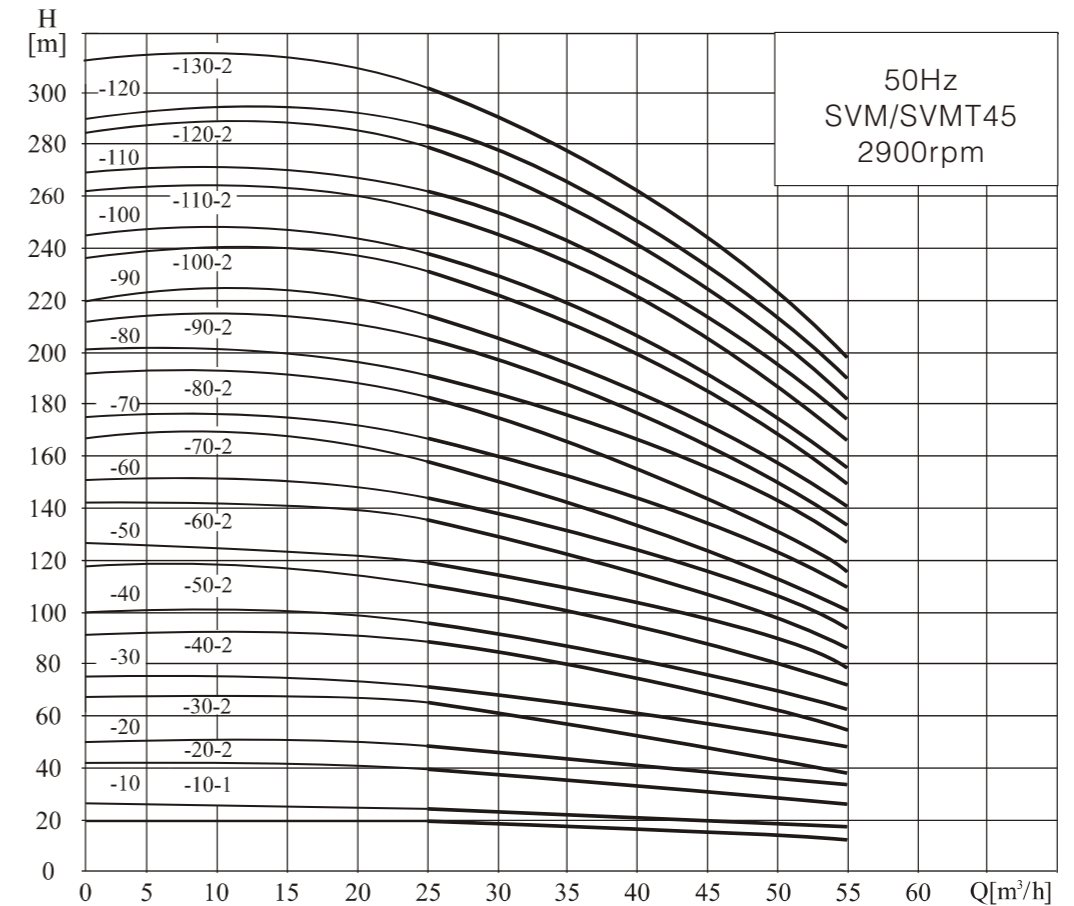

Installation dimensions and weight

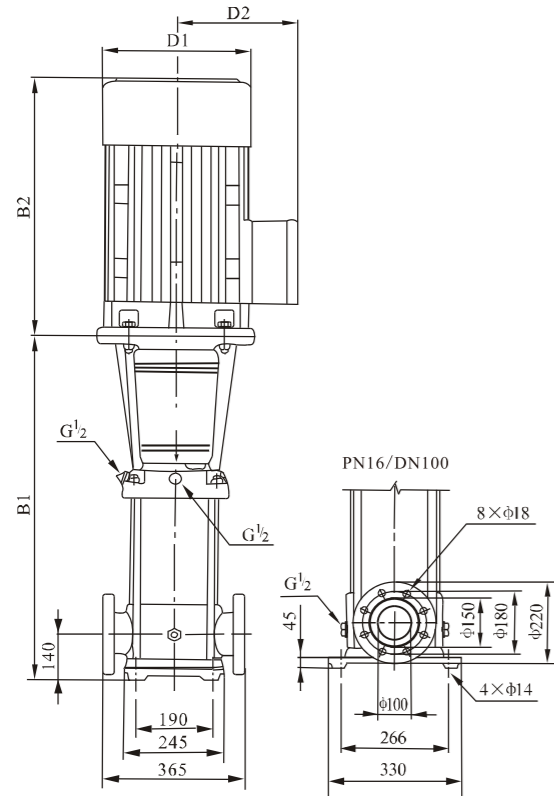

Model	Dimension (mm)					Weight (kg)
	B1	B2	B1+B2	D1	D2	
SVM(T)64-10-1	561	370	931	230	188	93
SVM(T)64-10	561	435	996	260	208	105
SVM(T)64-20-2	644	435	1079	260	208	110
SVM(T)64-20-1	754	580	1334	350	260	182
SVM(T)64-20	754	580	1334	350	260	182
SVM(T)64-30-2	836	580	1416	350	260	197
SVM(T)64-30-1	836	580	1416	350	260	197
SVM(T)64-30	836	610	1446	330	260	221
SVM(T)64-40-2	919	610	1529	350	260	225
SVM(T)64-40-1	919	645	1564	360	285	258
SVM(T)64-40	919	645	1564	360	285	258
SVM(T)64-50-2	1001	705	1706	400	310	317
SVM(T)64-50-1	1001	705	1706	400	310	321
SVM(T)64-50	1001	705	1706	400	310	321
SVM(T)64-60-2	1084	705	1789	400	310	325
SVM(T)64-60-1	1084	705	1789	400	310	349
SVM(T)64-60	1084	705	1789	400	310	349
SVM(T)64-70-2	1166	705	1871	400	310	353
SVM(T)64-70-1	1166	705	1871	400	310	353
SVM(T)64-70	1166	740	1906	460	340	420
SVM(T)64-80-2	1248	740	1988	460	340	424
SVM(T)64-80-1	1248	740	1988	460	340	424

Performance data

Model	Power		Q (m³/h)	H (m)						
	kW	Hp		30	40	50	60	64	70	80
SVM(T)64-10-1	4.0	5.5	19	18	16	14	13	11	8	
SVM(T)64-10	5.5	7.5	27	25	23	21	20	18	15	
SVM(T)64-20-2	7.5	10	39	36	33	29	27	23	17	
SVM(T)64-20-1	11	15	46	44	40	36	34	30	24	
SVM(T)64-20	11	15	53	51	47	43	41	37	30	
SVM(T)64-30-2	15	20	66	62	56	50	47	41	32	
SVM(T)64-30-1	15	20	73	69	63	57	54	48	39	
SVM(T)64-30	18.5	25	80	76	70	64	61	55	46	
SVM(T)64-40-2	18.5	25	92	87	80	71	67	60	47	
SVM(T)64-40-1	22	30	100	94	87	78	74	67	54	
SVM(T)64-40	22	30	107	101	94	85	81	74	61	
SVM(T)64-50-2	30	30	121	114	105	95	89	80	64	
SVM(T)64-50-1	30	40	128	121	112	102	96	87	71	
SVM(T)64-50	30	40	136	129	119	109	103	94	78	
SVM(T)64-60-2	30	40	150	142	131	118	111	101	81	
SVM(T)64-60-1	37	50	157	149	138	125	118	108	88	
SVM(T)64-60	37	50	164	156	145	132	125	115	95	
SVM(T)64-70-2	37	50	179	169	156	141	133	121	99	
SVM(T)64-70-1	37	50	186	176	163	148	141	128	106	
SVM(T)64-70	45	60	193	183	170	155	148	135	112	
SVM(T)64-80-2	45	60	207	196	182	164	156	142	116	
SVM(T)64-80-1	45	60	215	203	189	171	163	149	123	

Performance cruve

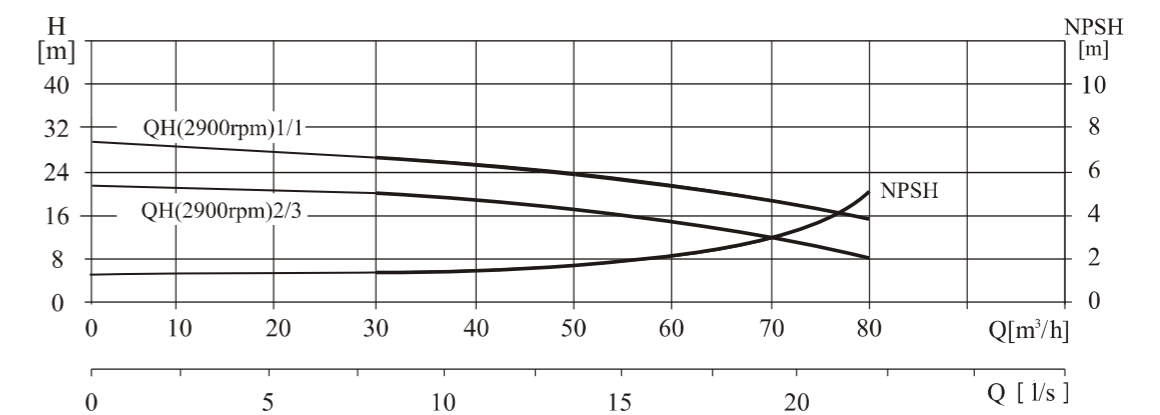
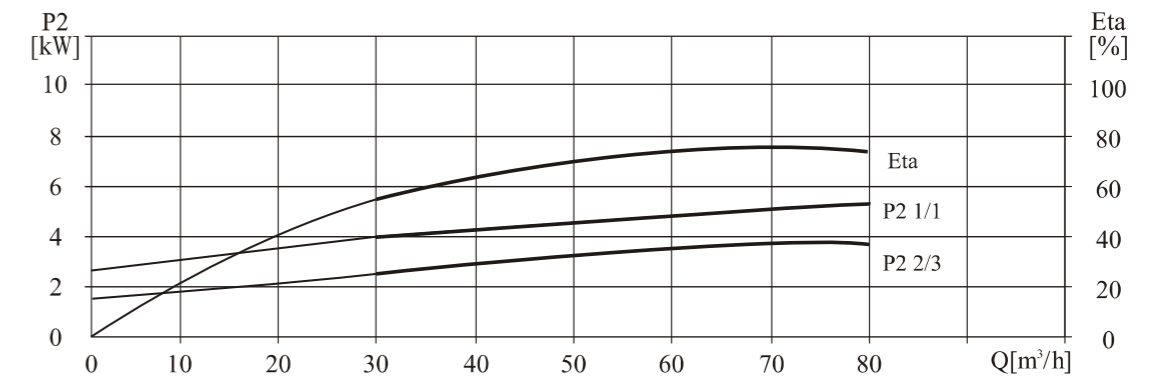
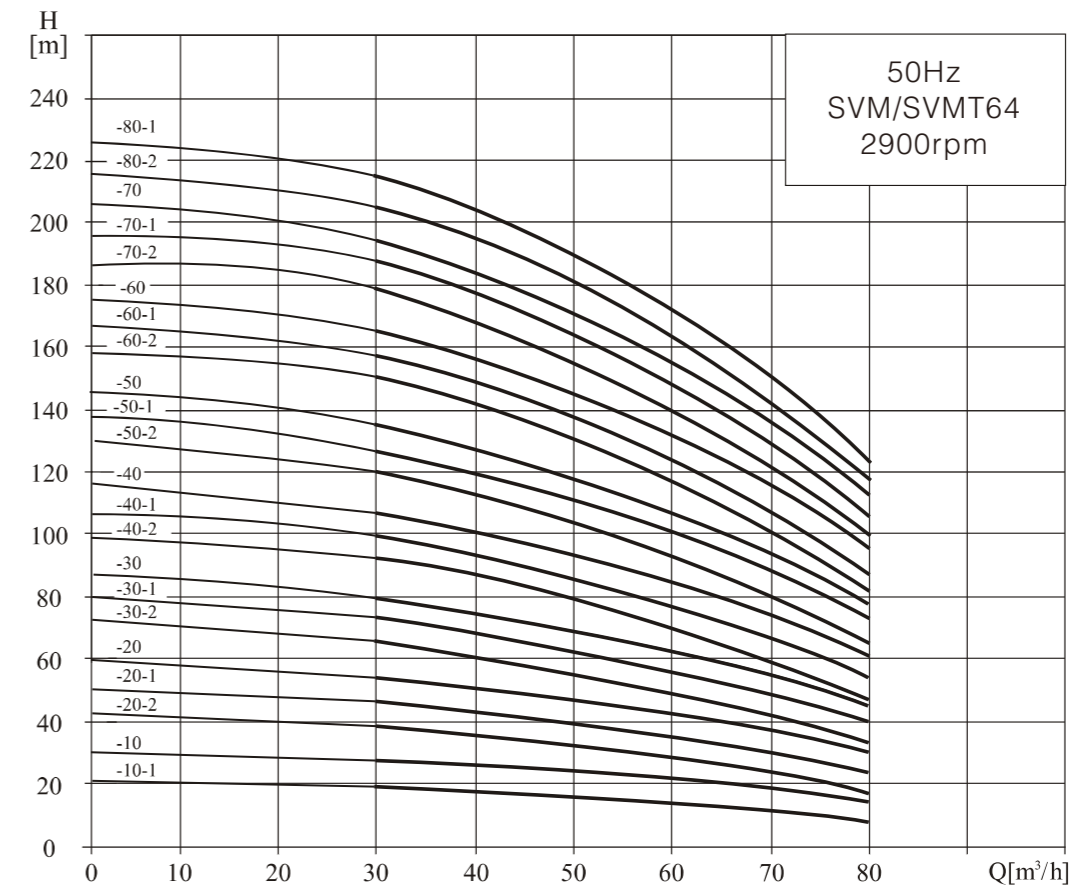

Installation dimensions and weight

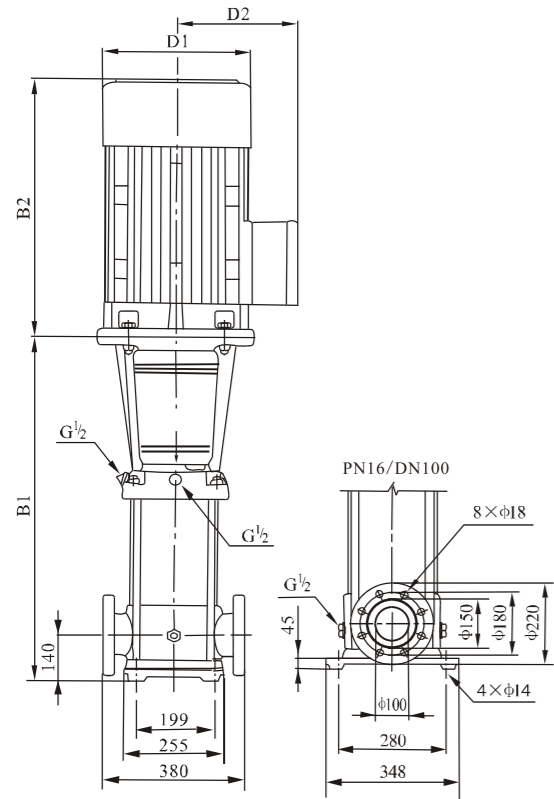

Model	Dimension (mm)					Weight (kg)
	B1	B2	B1+B2	D1	D2	
SVM(T)90-10-1	571	435	1006	260	208	105
SVM(T)90-10	571	435	1006	260	208	110
SVM(T)90-20-2	773	580	1353	350	260	181
SVM(T)90-20	773	580	1353	350	260	192
SVM(T)90-30-2	865	610	1475	350	260	215
SVM(T)90-30	865	645	1510	360	285	252
SVM(T)90-40-2	957	705	1662	400	310	312
SVM(T)90-40	957	705	1662	400	310	312
SVM(T)90-50-2	1049	705	1754	400	310	336
SVM(T)90-50	1049	705	1754	400	310	336
SVM(T)90-60-2	1141	740	1881	460	340	407
SVM(T)90-60	1141	740	1881	460	340	407

Performance data

Model	Power		Q (m³/h)	H (m)									
	kW	Hp		50	60	70	80	90	100	110			
SVM(T)90-10-1	5.5	7.5	H (m)	22	19	17	16	13	10	6			
SVM(T)90-10	7.5	10		25	24	22	21	19	16	12			
SVM(T)90-20-2	11	15		41	39	36	32	28	22	15			
SVM(T)90-20	15	20		53	50	47	44	40	36	30			
SVM(T)90-30-2	18.5	25		68	65	60	55	49	41	32			
SVM(T)90-30	22	30		81	77	72	67	62	55	48			
SVM(T)90-40-2	30	40		98	93	87	80	72	62	50			
SVM(T)90-40	30	40		110	105	100	92	84	76	66			
SVM(T)90-50-2	37	50		126	120	113	104	93	81	68			
SVM(T)90-50	37	50		139	131	124	115	106	94	83			
SVM(T)90-60-2	45	60		155	148	139	129	117	102	86			
SVM(T)90-60	45	60		168	160	150	141	130	117	103			

Performance cruve

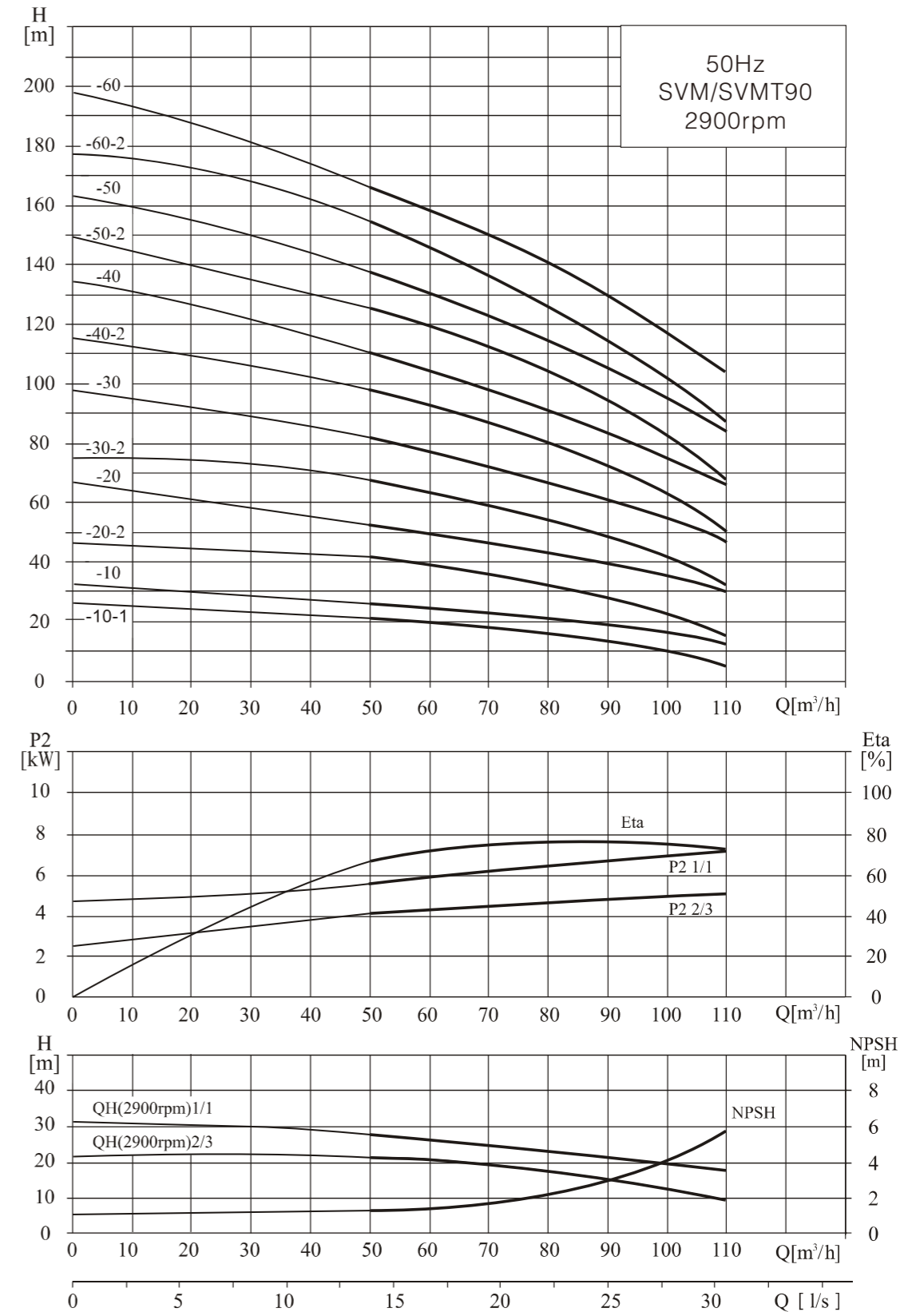

Installation dimensions and weight

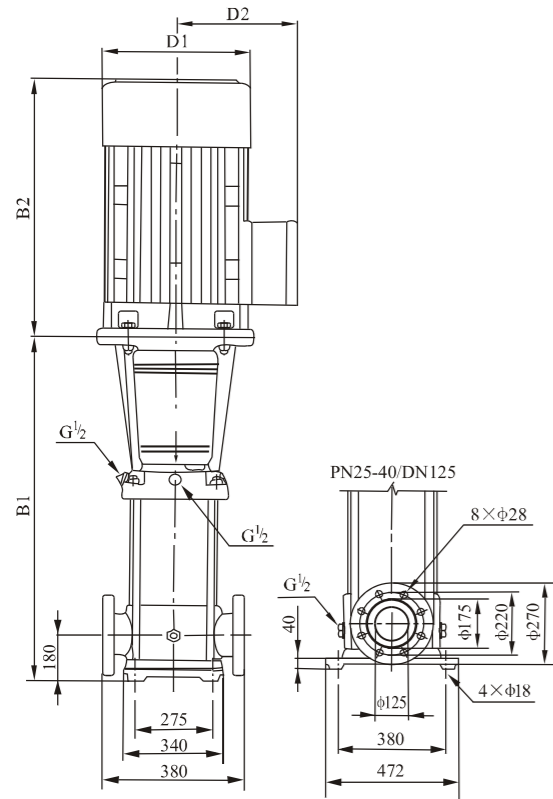

Model	Dimension (mm)					Weight (kg)
	B1	B2	B1+B2	D1	D2	
SVM(T)120-10	840	580	1420	350	260	230
SVM(T)120-20-2	1000	580	1580	350	260	245
SVM(T)120-20-1	1000	610	1610	350	260	250
SVM(T)120-20	1000	645	1645	360	285	285
SVM(T)120-30-2	1160	705	1865	400	310	358
SVM(T)120-30-1	1160	705	1865	400	310	360
SVM(T)120-30	1160	705	1865	400	310	360
SVM(T)120-40-2	1320	705	2025	400	310	400
SVM(T)120-40-1	1320	705	2025	400	310	400
SVM(T) 120-40	1320	740	2060	460	340	460
SVM(T)120-50-2	1480	740	2220	460	340	470
SVM(T)120-50-1	1480	740	2220	460	340	470
SVM(T) 120-50	1510	810	2320	550	370	575
SVM(T) 120-60-2	1670	810	2480	550	370	585
SVM(T) 120-60-1	1670	810	2480	550	370	585
SVM(T) 120-60	1670	870	2540	580	410	705
SVM(T)120-70-2	1830	870	2700	580	410	713
SVM(T)120-70-1	1830	870	2700	580	410	715
SVM(T)120-70	1830	870	2700	580	410	715

Performance data

Model	Power		Q (m³/h)	H (m)											
	kW	Hp		60	70	80	90	100	110	120	130	140	150		
SVM(T)120-10	11	15	22	21.8	21.6	21	20.5	19.5	18.5	17	16	15			
SVM(T)120-20-2	15	20	34	33.6	33	31	30.2	30	28.5	27	25	24			
SVM(T)120-20-1	18.5	25	41	40	39.5	38.5	37	36.5	34.5	32.5	30	27.5			
SVM(T)120-20	22	30	46	45	44.5	43.5	42.4	41	40	38	36	33.5			
SVM(T)120-30-2	30	40	57	56	55	53.5	52	51	49	46.5	43.5	41			
SVM(T)120-30-1	30	40	64	63	62	60	58.5	57.5	55.5	52	49	46			
SVM(T)120-30	30	40	69.5	68.5	67.5	66	64.4	62.5	61	57.5	54.5	51			
SVM(T)120-40-2	37	50	80.5	79	78	76	73.5	72	69	66	61.5	58			
SVM(T)120-40-1	37	50	87	86	84.5	82	80	78	76	72	68	64.5			
SVM(T) 120-40	45	60	92.5	91	90	88	85.5	83	81	77	73	68.5			
SVM(T)120-50-2	45	60	104.5	103	101	99	96	93	90	85.5	80.5	75.5			
SVM(T)120-50-1	45	60	110.5	109	107.5	105	102	100	97	92	86.5	83			
SVM(T)120-50	55	75	115.5	114	113	110	107.5	104.5	101.5	96	91	86			
SVM(T)120-60-2	55	75	128	125.5	123	121	117.3	113.5	110	104.5	98.5	92.5			
SVM(T)120-60-1	55	75	134	132	130.5	127	124	121	118	111	105	100			
SVM(T)120-60	75	100	139	137	135	132	128.8	126	123	116	110	104			
SVM(T)120-70-2	75	100	151	148	145.5	143	138.6	134	130	123.5	116.5	109			
SVM(T)120-70-1	75	100	156.5	154	152	148.5	144.5	141	137.5	130	123	116.5			
SVM(T)120-70	75	100	162.5	160.5	158.5	155	151	148	145	137	129	123			

Performance cruve

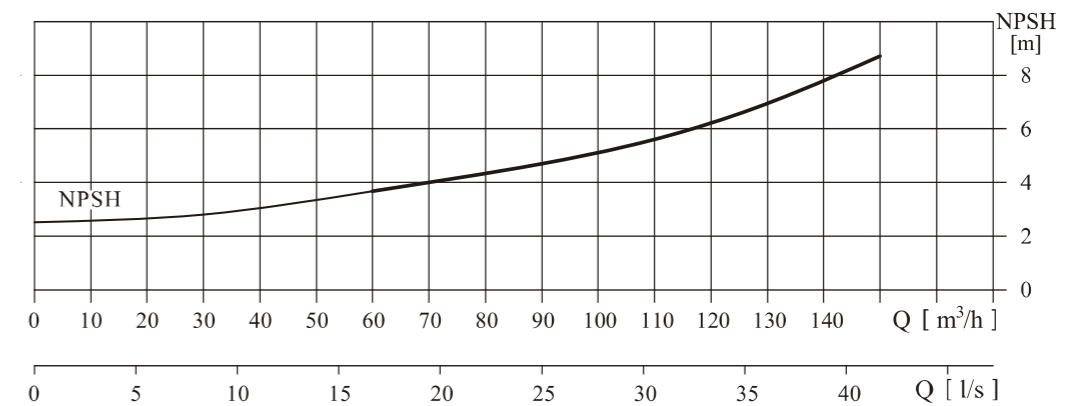
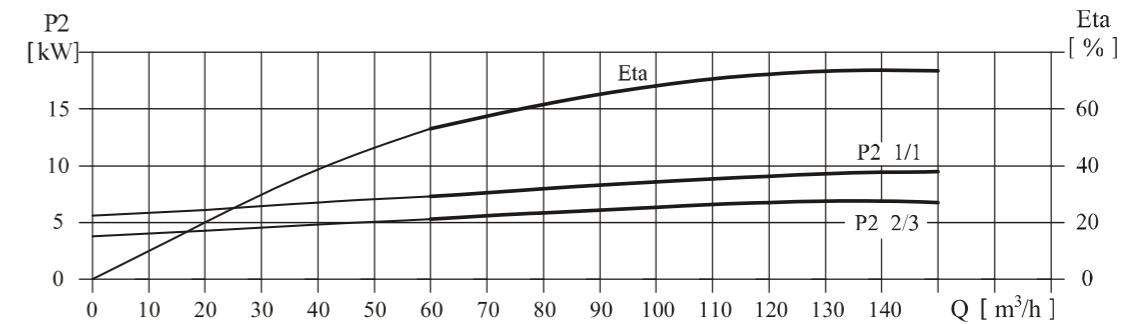
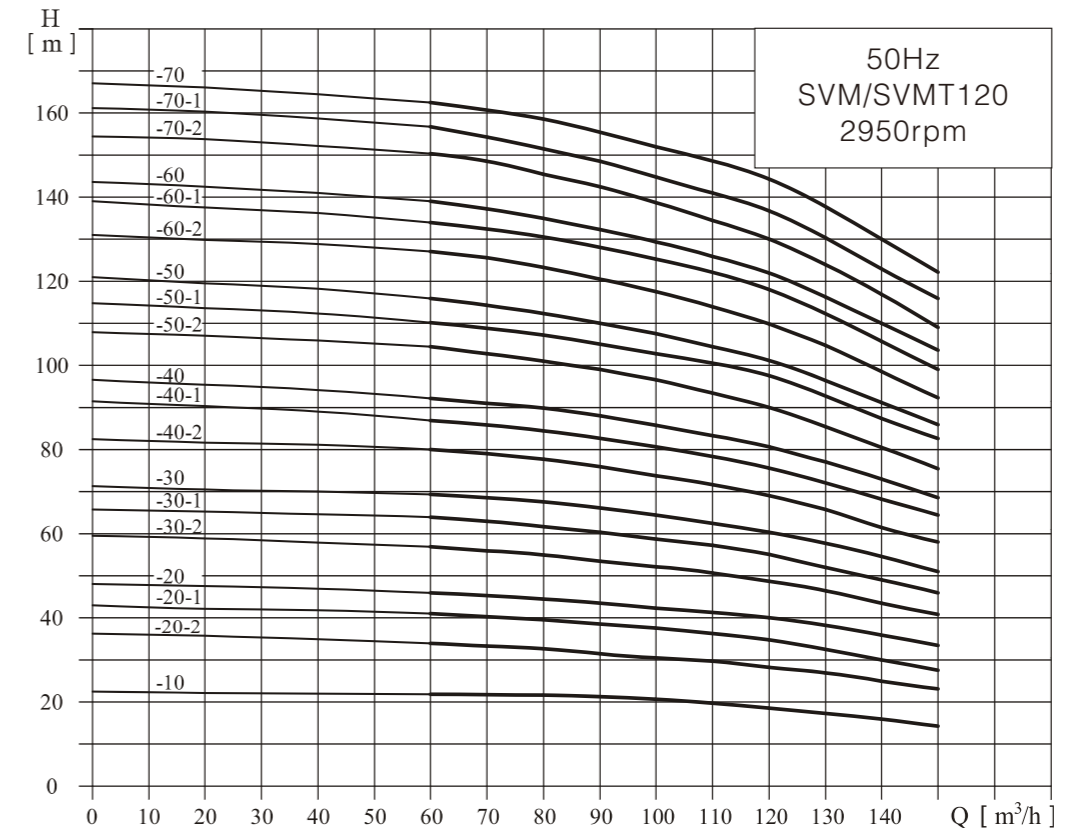

Installation dimensions and weight

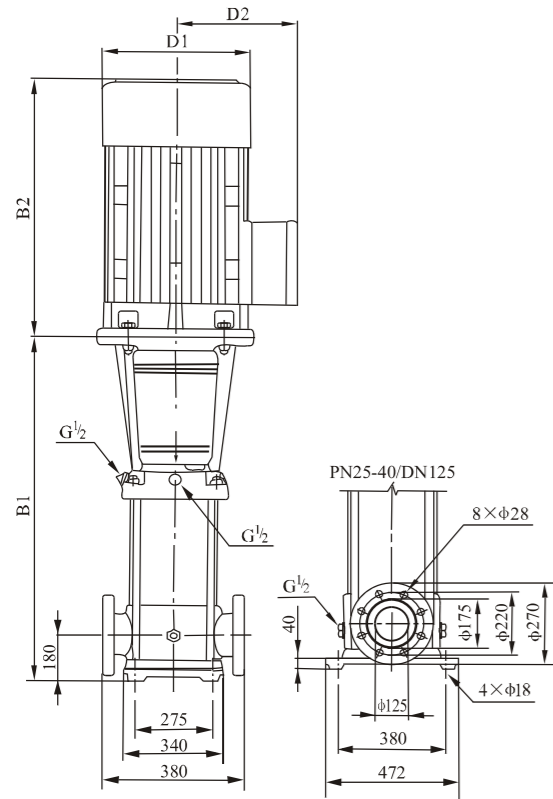

Model	Dimension (mm)					Weight (kg)
	B1	B2	B1+B2	D1	D2	
SVM(T)150-10-1	840	580	1420	350	260	235
SVM(T)150-10	840	580	1420	350	260	235
SVM(T)150-20-2	1000	610	1610	350	260	250
SVM(T)150-20-1	1000	645	1645	360	285	295
SVM(T)150-20	1000	705	1705	400	310	350
SVM(T)150-30-2	1160	705	1865	400	310	360
SVM(T)150-30-1	1160	705	1865	400	310	385
SVM(T)150-30	1160	705	1865	400	310	385
SVM(T)150-40-2	1320	740	2060	460	340	460
SVM(T)150-40-1	1320	740	2060	460	340	460
SVM(T)150-40	1350	810	2160	550	370	560
SVM(T)150-50-2	1510	810	2320	550	370	570
SVM(T)150-50-1	1510	870	2380	580	410	690
SVM(T)150-50	1510	870	2380	580	410	690
SVM(T)150-60-2	1670	870	2540	580	410	700
SVM(T)150-60-1	1670	870	2540	580	410	703
SVM(T)150-60	1670	870	2540	580	410	703

Performance data

Model	Power		Q (m³/h)	H (m)											
	kW	Hp		80	90	100	110	120	130	140	150	160	170	180	
SVM(T)150-10-1	11	15	18.3	17.8	17.3	17	16	15	14	12.5	11	10	8.5		
SVM(T)150-10	15	20	24	23	22.5	22	21.5	20.5	20	18.5	17	16	15		
SVM(T)150-20-2	18.5	25	37	35.5	34	33	32	31	29	27.5	26	23	21		
SVM(T)150-20-1	22	30	44.3	43	42	40	39	38.5	37.5	35	33	30	27		
SVM(T)150-20	30	40	50	49	48	47	45.5	44	42	40	37	34	32		
SVM(T)150-30-2	30	40	63.5	61	59	57.5	56	54.5	53	49	45.5	42	39		
SVM(T)150-30-1	37	50	70	68	67	65	63	62	60	56	53	49	45		
SVM(T)150-30	37	50	78	76.5	75	73	70.5	68	66	63	59	55	50.5		
SVM(T)150-40-2	45	60	89	87	84	81.5	79	77	74.5	70.5	65.5	60	56		
SVM(T)150-40-1	45	60	96.5	94	91.5	89	86.5	84	81.5	77	72.5	67	62		
SVM(T)150-40	55	75	104	102	100	97	95	91	88	84	79.5	74	68		
SVM(T)150-50-2	55	75	115.5	112	109	106	102.5	100	97	92	86	79	73.5		
SVM(T)150-50-1	75	100	122.5	119.5	117	113.5	111.5	107.5	104.5	99	93.5	87	80		
SVM(T)150-50	75	100	130	127.5	125	121	119	115	111.5	106.5	101	94.5	86.5		
SVM(T)150-60-2	75	100	140	137	133	130	126	121	118	112	106	98	91		
SVM(T)150-60-1	75	100	148.5	145	141.7	137.5	135	131	127	120.5	114.5	106.5	97.5		
SVM(T)150-60	75	100	157	153	149	145	142	139.5	137	130	123.5	116	109		

Performance cruve

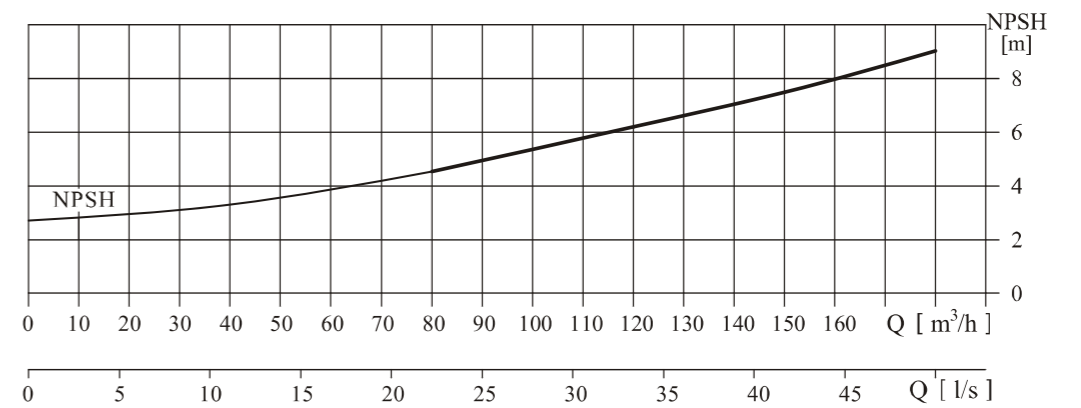
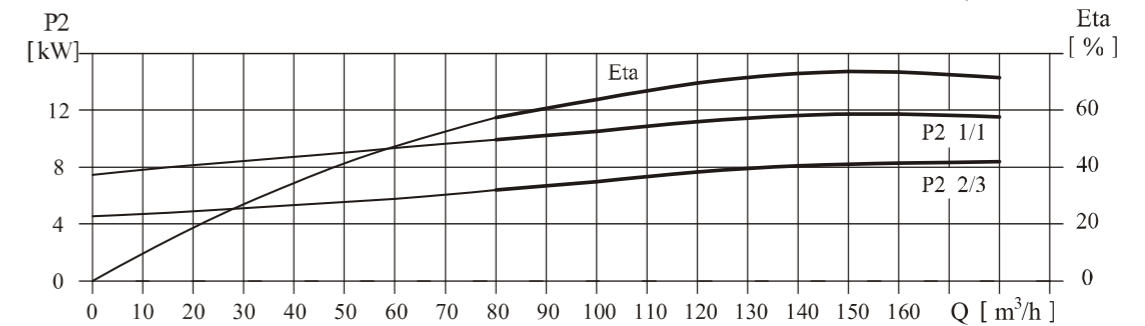
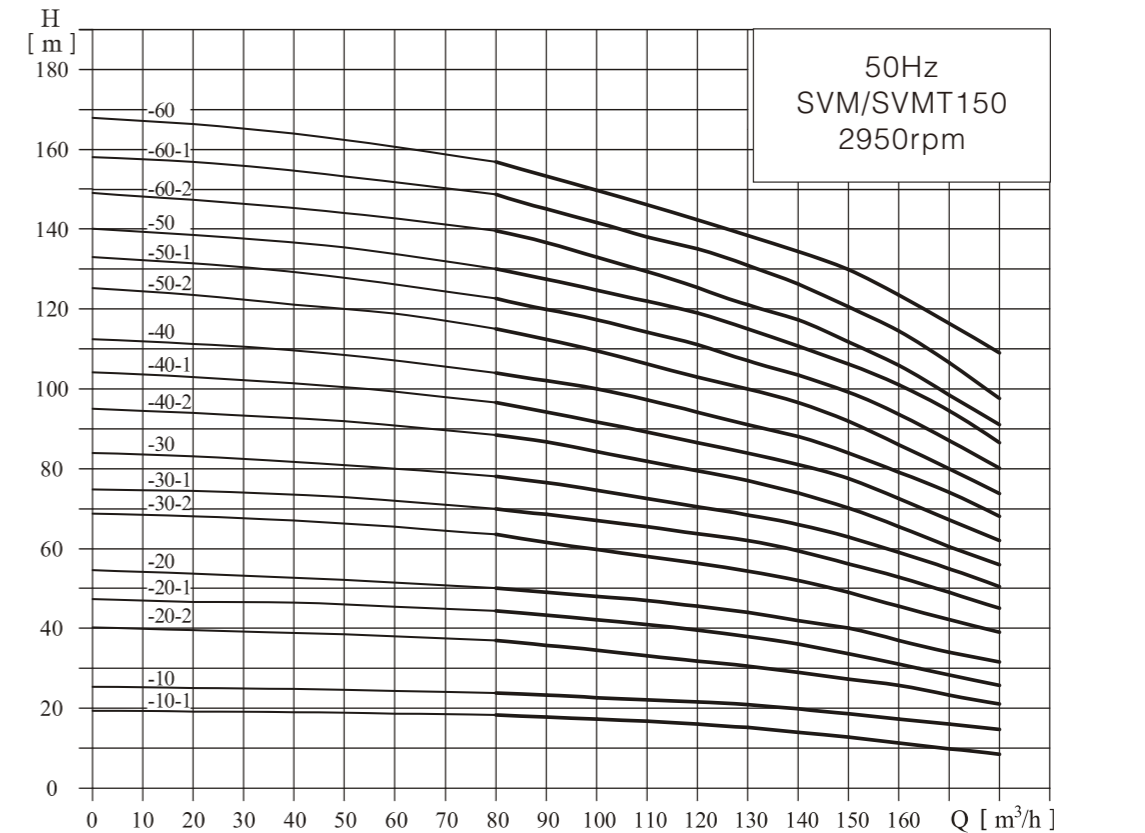

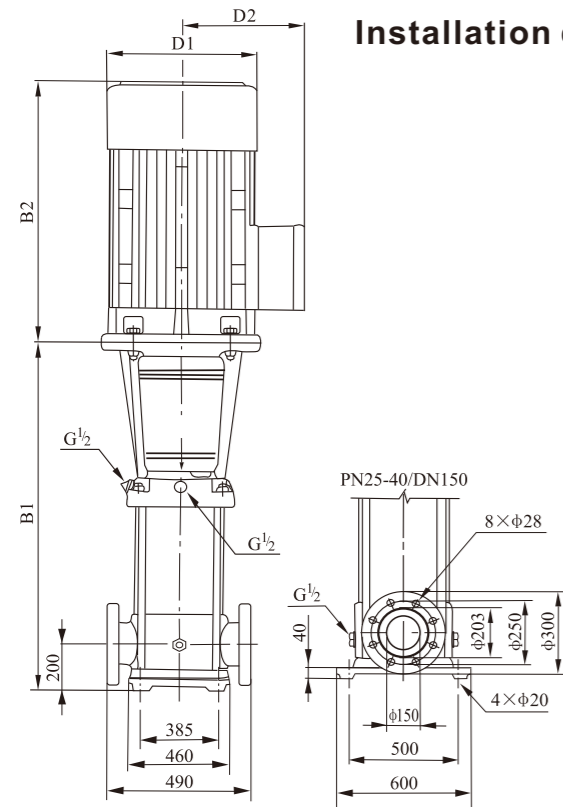

Installation dimensions and weight

Model	Dimension (mm)					Weight (kg)
	B1	B2	B1+B2	D1	D2	
SVM(T)200-10-B	907	610	1517	350	260	311
SVM(T)200-10-A	907	645	1552	360	285	347
SVM(T)200-10	907	705	1612	400	310	403
SVM(T)200-20-2B	1101	705	1806	400	310	447
SVM(T)200-20-2A	1101	740	1841	460	340	504
SVM(T)200-20-A	1131	810	1941	550	370	595
SVM(T)200-20	1131	810	1941	550	370	595
SVM(T)200-30-2B	1325	870	2195	580	410	748
SVM(T)200-30-A-B	1325	870	2195	580	410	748
SVM(T)200-30-2A	1325	870	2195	580	410	748
SVM(T)200-30-B	1325	870	2195	580	410	748
SVM(T)200-30-A	1325	870	2195	580	410	748
SVM(T)200-30	1325	920	2245	580	410	816
SVM(T)200-40-2B	1519	920	2439	580	410	830
SVM(T)200-40-2A	1519	1060	2579	660	550	1180
SVM(T)200-40-A	1519	1060	2579	660	550	1180
SVM(T)200-40	1519	1060	2579	660	550	1180

Performance data

Model	Power		Q (m³/h)	H (m)																	
	kW	Hp		100	120	140	160	180	200	220	240										
SVM(T)200-10-B	18.5	25	25.5	25	24	23	21.5	20	18	15.5											
SVM(T)200-10-A	22	30	29	28.5	27.5	26.5	25.5	24	22	20											
SVM(T)200-10	30	40	38.5	38	37.5	36.5	35	34	32.5	30											
SVM(T)200-20-2B	37	50	53	51	49	47	44	41	37	32											
SVM(T)200-20-2A	45	60	59.5	58	56	54	52.5	49	44.5	40.5											
SVM(T)200-20-A	55	75	69	68	66	64	62	59	55.5	51											
SVM(T)200-20	55	75	78.5	77.5	76	74	71.5	69	66	61.5											
SVM(T)200-30-2B	75	100	91.5	89	86.5	83.5	79	75	70	63											
SVM(T)200-30-A-B	75	100	95	93	90	87	83.5	79	73.5	67											
SVM(T)200-30-2A	75	100	99.5	97.5	94.5	91.5	89	84	78.5	72											
SVM(T)200-30-B	75	100	104.5	102.5	100	97	93	89	84.5	77.5											
SVM(T)200-30-A	75	100	108	106	103.5	100.5	97.5	93	88	81.5											
SVM(T)200-30	90	120	117.5	116	113.5	110.5	107	103	99	92											
SVM(T)200-40-2B	90	120	131.5	129	125.5	121	115.5	110	103.5	94											
SVM(T)200-40-2A	110	150	138.5	136	132	128	124	118	111	102.5											
SVM(T)200-40-A	110	150	148	145.5	142.5	138	134	128	122	113											
SVM(T)200-40	110	150	157.5	155.5	152.5	148	143.5	138	132.5	123.5											

Performance curve

